

## 46–480 Adjustment of power steering in vehicle

Steering LS 90 only

Adjusting value	Ncm	(kpcm)
Total friction torque of steering measured at steering worm	120–160	(12–16)

Tightening torques	Nm	(kpm)
Hex. collar nut at adjusting screw	60–70	(6–7)
Castle nut at drag link and track rod	35	(3.5)

### Special tools

Puller for ball joints of track rod and drag link on pitman arm		111 589 08 33 00
---	---	------------------

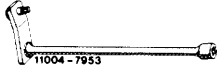
Allen wrench insert		123 589 01 10 00
---------------------	--	------------------

Box wrench		123 589 01 03 00
------------	--	------------------

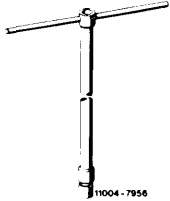
Socket wrench		123 589 01 09 00
---------------	---	------------------

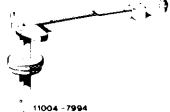
Torque wrench 1/2" square 0–400 Ncm (0–40 kpcm)		123 589 02 21 00
---	---	------------------

### Conventional tools

Allen wrench insert 3/8" with joint for hex. socket screw 6 mm	e. g. made by Hazet order No. 2740
Slide handle 3/8" 200 mm long	e. g. made by Hazet order No. 8815
Extension 3/8" 255 mm long	e. g. made by Hazet order No. 8821–10

1 Uncotter castle nut of drag link and track rod on pitman arm and unscrew castle nut.

2 Remove ball joint of drag link (21) and track rod (20) with puller (35).

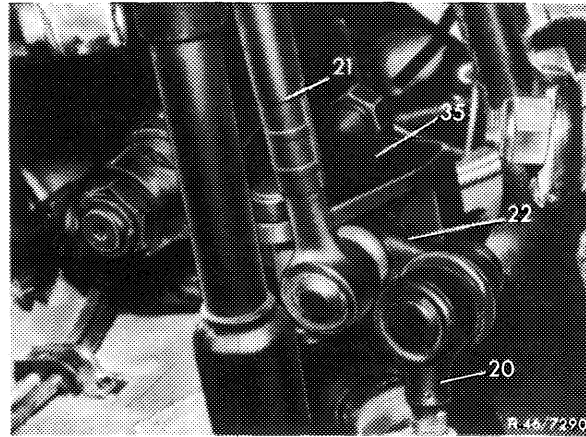

3 Remove company symbol from pad of steering wheel by means of a small screw driver.

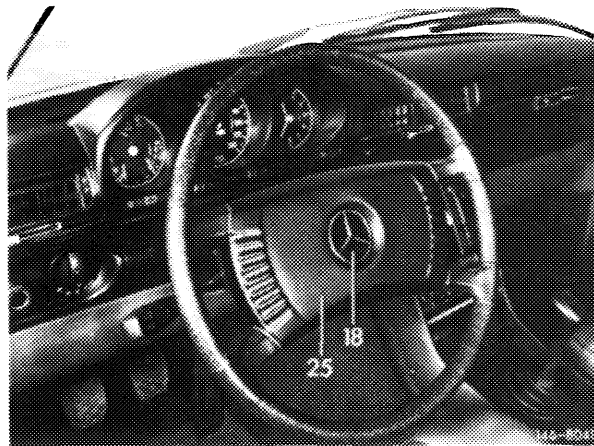

4 Turn steering several times from lock to lock with torque wrench (060) while measuring friction torque.

**Note:** Insert centering sleeve (061) into steering wheel to guide torque wrench well while measuring.

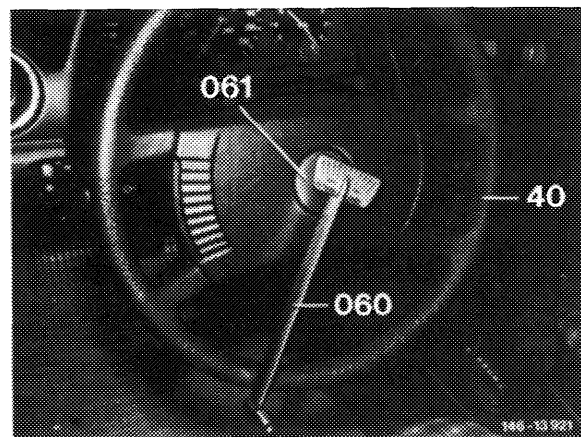

5 Readjust steering, when friction torque is not above basic friction value when turning beyond center position range.

**Note:** a) Friction torque of a new steering gear:  
Friction torque in center position 160 Ncm (16 kpcm)  
Basic friction value 100 Ncm (10 kpcm).

Torque flow (without power pressure) over total steering range. Drive by means of steering worm

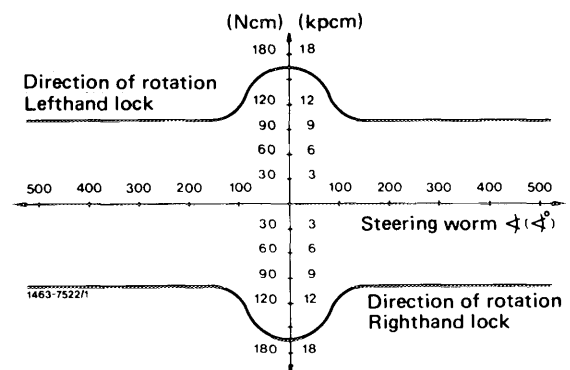

b) Friction torque of used steering gear:  
Friction torque dropped to 50 Ncm (5 kpcm) over entire turning, no friction increase in center range.

**Attention!**

**If torque increases above 120 Ncm (12 kpcm) in center range of steering (90° on steering wheel) the steering may not be readjusted.**

Torque flow (without power pressure) over total steering range. Drive by means of steering worm

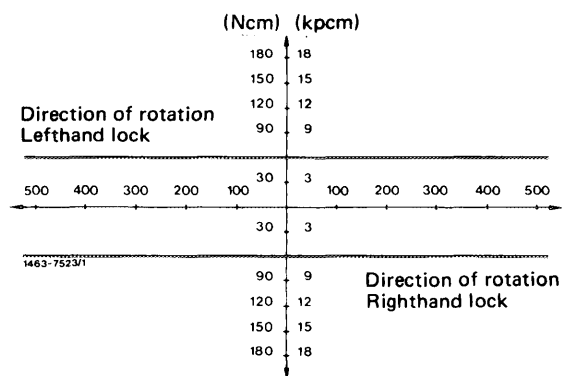

6 Adjust steering by loosening hex. collar nut (57) and turning adjusting screw (47) by 1/4 turn to the left. Tighten hex. collar nut to 60–70 Nm (6–7 kpcm).

**Note:** Unscrewing of adjusting screw by 1/4 turn increases friction torque by approx. 50–70 Ncm (5–7 kpcm).

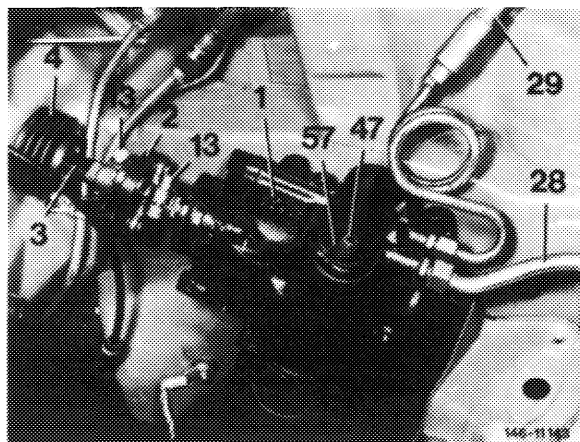

7 Measure friction torque with torque wrench once again over center position. **Friction torque should be 50–70 Ncm (5–7 kpcm) over basic friction torque.**

If this increase is not attained, unscrew adjusting screw once again by 1/8 to 1/4 turn.

**When turning over center position, the total friction torque should not exceed 160 Ncm (16 kpcm).**

8 Use of special tools and conventional tools:

**Models 115.1, 115.0, 114.01**

For adjustment, use socket wrench part No. 123 589 01 09 00 (065) together with slide handle (062), extension (063) and Allen wrench insert with joint.

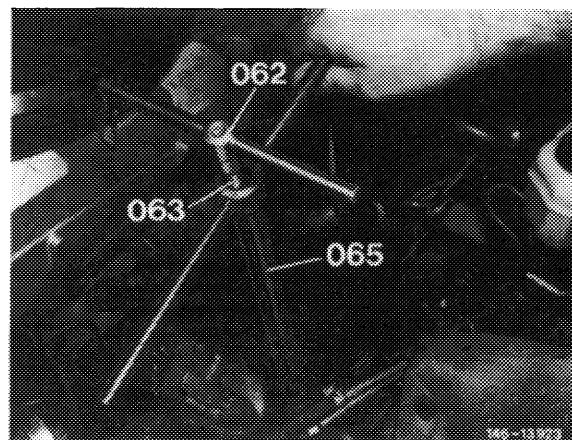

**Models 114.06, 114.07**

For loosening or tightening hex. collar nuts from below, use box wrench part No. 123 589 01 03 00 (067).

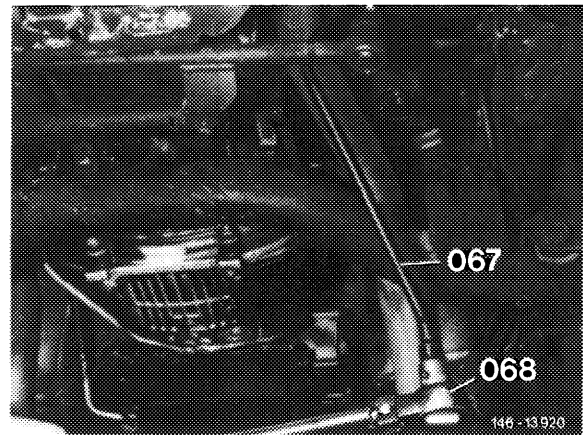

Adjustment of adjusting screw requires: Allen wrench with joint, extension and slide handle.

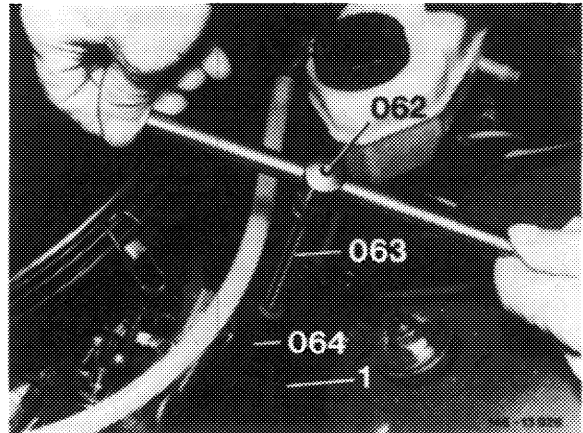

9 Check rubber sleeve on joint of track rod. If sleeve is damaged, check joint for wear and replace, if required.

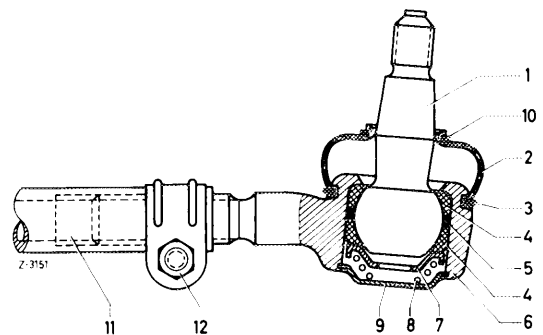

10 Check joint of drag link for wear and replace drag link, if required. Place sealing ring (3) and plastic cover (2) on ball joint.

11 Attach track rod and drag link to pitman arm, cotter castle nut. Tightening torque 35 Nm (3.5 kpm) reference value.

12 Insert company symbol into steering wheel.

