

Check steering components very carefully. When in doubt, the pertinent part should be replaced.

Notes

The ball circuit, that is, the steering worm and the steering nut, is assembled free of play at the factory.

To maintain the specified play of 0.006 to 0.01 mm between the straightedge of the steering nut and the control valve, both parts are assembled by the selection system.

The same applies to the steering housing and its control valve. For this reason, available spare parts in addition to the sealing and bearing assembly include the pitman shaft, the bearing cap and the bearing insert, as well as the housing cover only.

Steering worm

1 Check ball circuit on steering worm (3). If evidence of wear is shown, replace steering.

- 3 Steering worm
- 7 Bearing cap
- 9 Bearing insert
- 28 O-ring
- 29 O-ring
- 30 Sealing ring (Teflon)
- 31 Slot nut
- 32 Axial cyl. roller cage
- 61 Axial washer

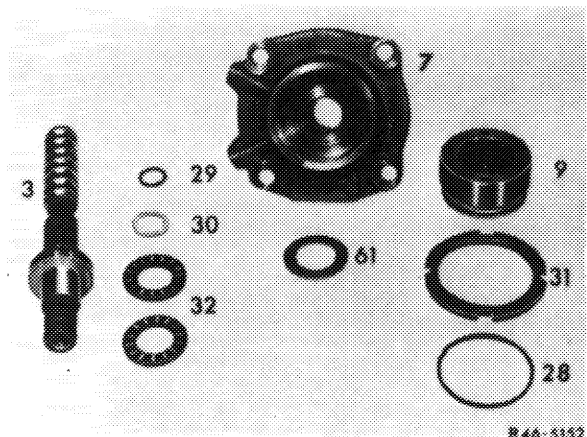

Bearing insert

2 Check needle sleeve (25) for wear. If needle sleeve is damaged, completely renew bearing insert (9).

Power piston and steering nut

3 Remove sealing ring (41) and O-ring (40) from power piston (5). Press outer race of axial tapered ball bearing (33) out of power piston.

4 Remove sealing ring (38) and O-ring (37) from screw cover (36).

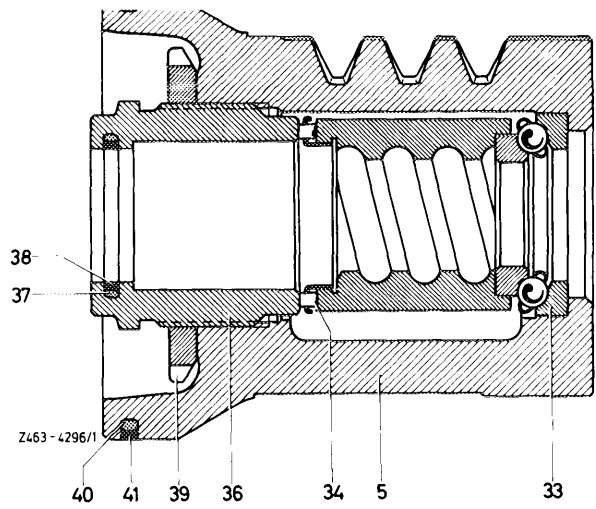

5 Check ball circuit in steering nut (4). If there is evidence of wear, replace steering.

- 4 Steering nut
- 4a Straightedge on steering nut
- 5 Power piston
- 33 Axial tapered ball bearing
- 34 Axial cyl. roller cage
- 36 Screw cover
- 39 Slot nut
- 41 Sealing ring (Teflon)

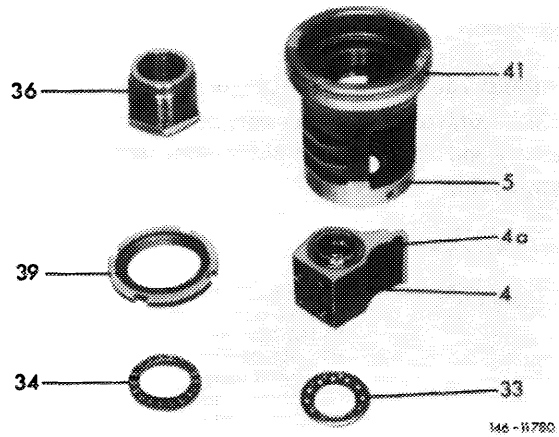

Pitman shaft

6 Check pitman shaft (2) for wear at bearing points and for distortion or other damage. Replace pitman shaft, if required.

- 2 Pitman shaft
- 27 Adjusting screw
- 48 Thrust washer
- 49 Locking ring
- 50 Thrust ring
- 51 Locking ring

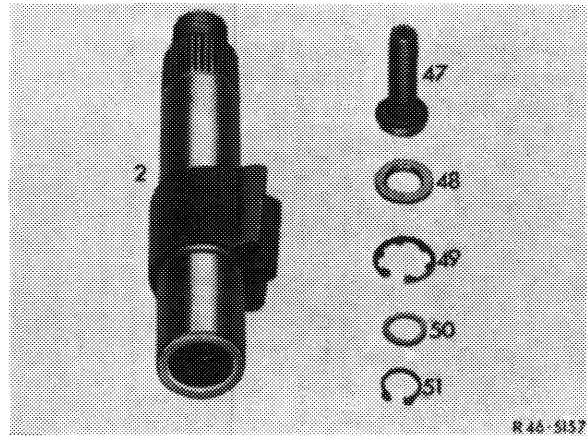

Housing cover

7 Check needle sleeve (52) for wear. If needle sleeve is damaged, completely replace housing cover.

Steering gear housing

8 Check needle sleeve in steering gear housing for wear. If required, pull out needle sleeve with a conventional puller.

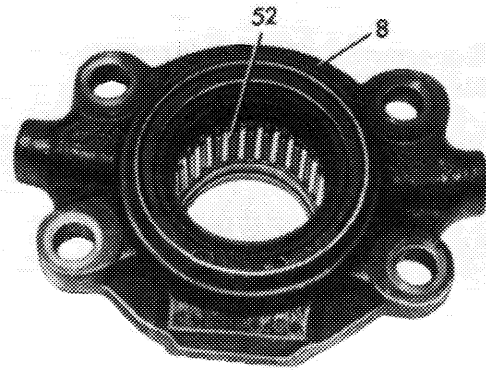

Control valve

Note: On 1st version of control valve the reaction pistons are 11 mm thick and the supporting bolts (13) are locked in the reaction pistons by means of locking rings (14). On 2nd version, (production as from the middle of 1972) the diameter of the reaction pistons (12) is 10 mm. The two spring bolts (65) are inserted in the reaction pistons. On control valve 3rd version (production as from the end of 1973), reaction pistons (12) with a diameter of 11 mm are installed. Compensating washer (66) and spring (67) are installed in reaction piston. As from the begin of 1976, control valve 4th version will be installed, with reaction pistons of 11.5 mm dia.

1st version

9 Check reaction piston (12) and supporting bolt (13) in control valve (6) for easy operation. If required, remove and clean reaction piston after removal of locking ring (16).

- 6 Control valve
- 12 Reaction piston (11 mm dia.)
- 13 Supporting bolt
- 16 Locking ring
- 18 Thrust washer
- 19 Compression spring
- 20 Locking ring

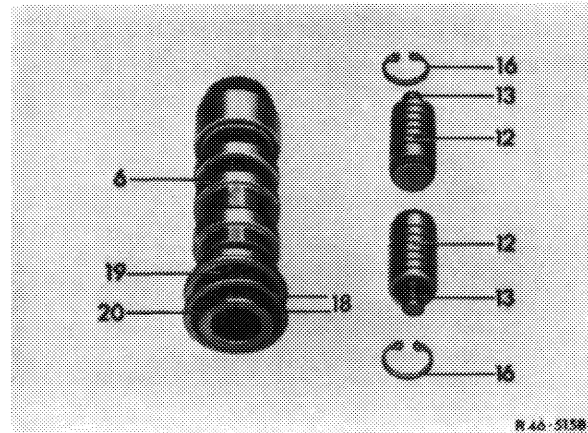

Note: Do not remove supporting bolts (13) from reaction piston (12), since the spring preload of compression spring (15) has been adjusted by means of compensating washers (17).

- 6 Control valve
- 12 Reaction piston
- 13 Supporting bolt
- 14 Locking ring
- 15 Compression spring
- 16 Locking ring
- 17 Compensating washer
- 18 Thrust washer
- 19 Compression spring
- 20 Locking ring

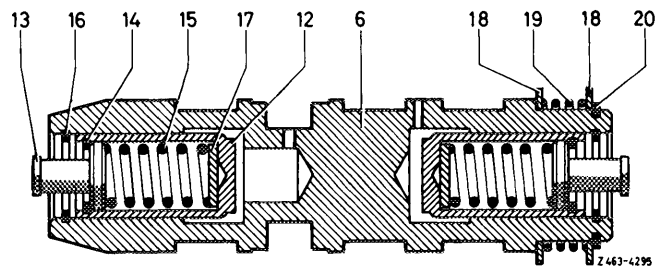

2nd version

10 Check reaction piston (12) in control valve (6) for easy operation.

- 6 Control valve
- 12 Reaction piston (10 mm dia.)
- 15 Compression spring
- 16 Locking ring
- 17 Compensating washer
- 18 Thrust washer
- 19 Compression spring
- 20 Locking ring
- 65 Spring bolt

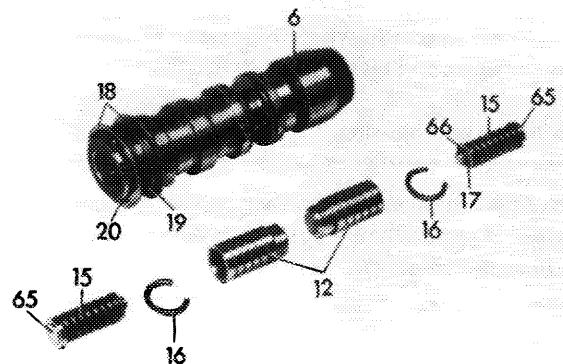

Note: Do not disassemble spring bolts (65), since spring preload is adjusted with compensating washers (17).

- 6 Control valve
- 12 Reaction piston (10 mm dia.)
- 15 Compression spring
- 16 Locking ring
- 17 Compensating washer
- 18 Thrust washer
- 19 Compression ring spring
- 20 Locking ring
- 65 Spring bolt

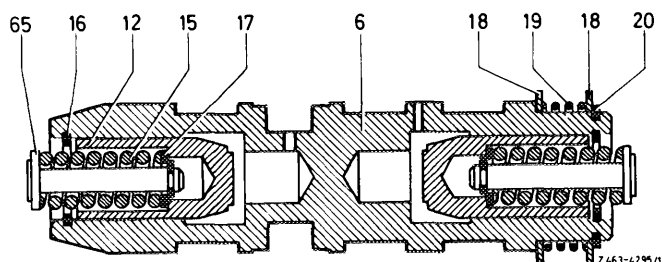

3rd and 4th version

11 Check reaction piston (12) in control valve (6) for easy operation.

Note: Do not confuse spring (15) and compensating washers (17) on each of the two reaction pistons.

- 6 Control valve
- 12 Reaction piston (11 or 11.5 mm dia.)
- 15 Compression spring
- 16 Locking ring
- 17 Compensating washer
- 18 Thrust washer
- 19 Compression spring
- 20 Locking ring

