

Adjusting data	Ncm	(Kpcm)
Friction torque new ball circuit	15-20	(1.5-2.0)
Friction torque of used ball circuit min.	3	(0.3)
Increase of friction torque with sealing ring mounted	8-10	(0.8-1.0)

**Special tool**

Adjusting tool for friction

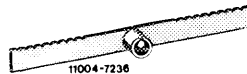

116 589 03 21 00

**Self-made tools**

Assembly bolt for sealing ring

refer to illustration item 1

Assembly bolt for needle sleeve

refer to illustration item 3

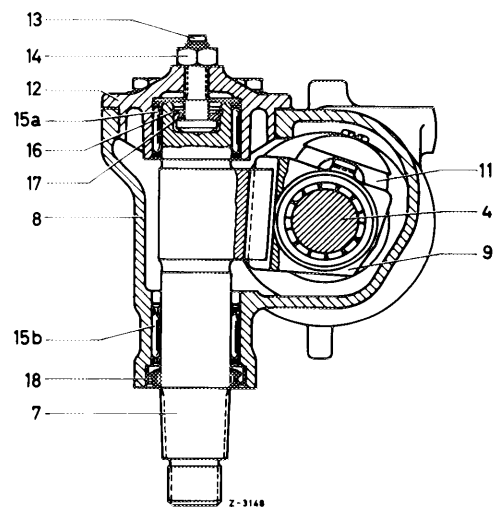
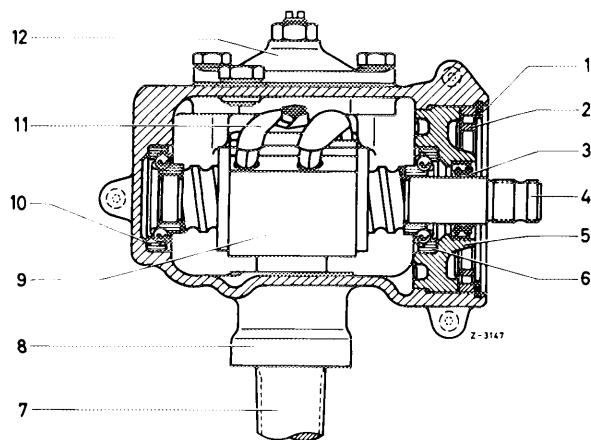

- 1 Locking ring
- 2 Threaded ring
- 3 Sealing ring
- 4 Steering worm
- 5 Adjusting ring

- 6 Tapered ball bearing
- 7 Pitman shaft
- 8 Steering housing
- 9 Steering nut
- 10 Tapered ball bearing

- 11 Ball guide
- 12 Housing cover
- 13 Adjusting screw
- 14 Hex. nut
- 15a Upper needle bearing

- 15b Lower needle bearing
- 16 Locking ring
- 17 Spacing washer
- 18 Locking ring

**When appraising steering components for reuse, strict criteria should be applied.**

**1. Steering nut and steering worm**

Check ball races for scoring, wear marks or other damage.

The ball guide tubes (11) on steering nut (9) should not show any evidence of damage.

**If damaged, replace steering nut and steering worm with ball together.**

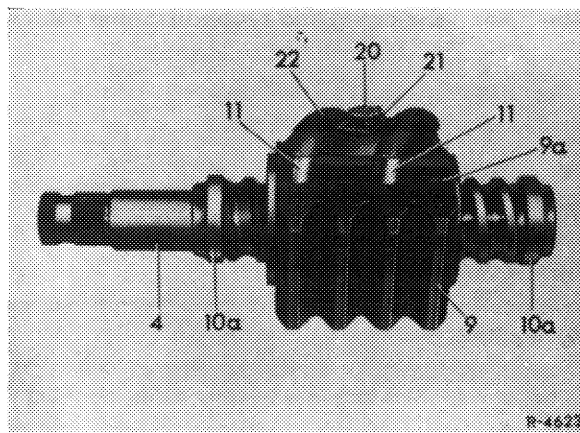

Clamp steering nut into vise by means of aluminum jaws and measure friction torque of ball circuit. The friction torque should be as follows:

New ball circuit 15–20 Ncm (1.5–2 kpcm) = 200 g weight in notch 7 to 10

Used ball circuit 3 Ncm (0.3 kpcm) = 50 g weight in notch 6.

If a friction torque less than 3 Ncm (0.3 kpcm) is measured, completely renew ball circuit (steering worm and steering nut).

During assembly, components are selected to provide the specified friction torque.

Press a new sealing ring into adjusting ring by means of assembly bolt. Fill sealing ring with grease between both sealing lips.

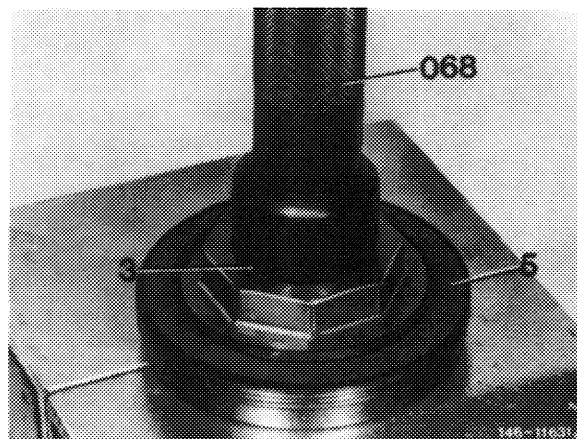
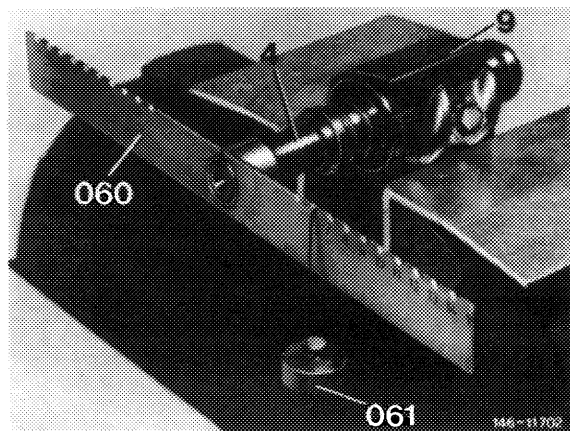

The assembly bolt must be self-made according to specified dimensions.

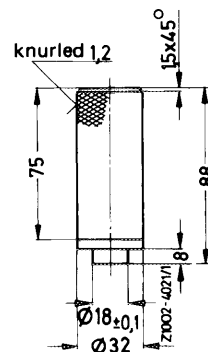

Check friction torque of ball circuit with sealing ring installed, while holding adjusting ring in position. With the sealing ring installed, the friction torque may be higher by 8–10 Ncm (0.8 to 1.0 kpcm).

New ball circuit 200 g weight in notch 11 to 14.

Used ball circuit 200 g weight in notch 5 to 6.

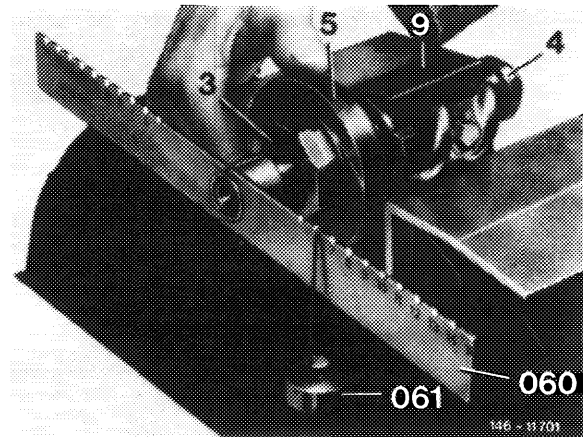

## 2. Pitman shaft

Check for wear at bearing points, for distortion or other damage.

## 3. Steering housing

Check housing for damage and needle sleeve for wear and renew, if required. For this purpose, knock needle sleeve out of steering housing by means of assembly bolt.

Press new needle sleeve into housing by means of assembly bolt. The assembly bolt must be set on marked side of needle sleeve.

**Note:** The assembly bolt must be self-made according to specified dimensions.

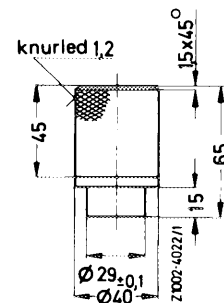

## 4. Steering housing cover

Check steering housing cover for flatness. In the event of worn or dented spots in upper needle bearing, completely renew housing cover.

## 5. Tapered ball bearing

Check bearing races including cage and balls for scores or other damages.