

Note

Measuring rocker arm requires repair kit, part no. 000 586 08 43.

Disassembly

- 1 Remove diaphragm (42-620).
- 2 Relieve both pressure springs (14 and 21) by turning screw spindle in assembly plate back. Remove vacuum pump from assembly plate.
- 3 Remove upper spring retainer (23) and both compression springs (14 and 21) from diaphragm rod (17).

- 2 Plate valve (suction end)
- 3 Hex. socket screw
- 4 Diaphragm
- 5 Plate valve
- 6 Closing cover
- 7 Gasket
- 8 Pump housing
- 9 Pump cover
- 10 Diaphragm disc
- 14 Outer compression spring
- 15 Lower spring retainer
- 16 Roller
- 17 Diaphragm rod
- 21 Inner compression spring
- 22 Guide bushing
- 23 Upper spring retainer

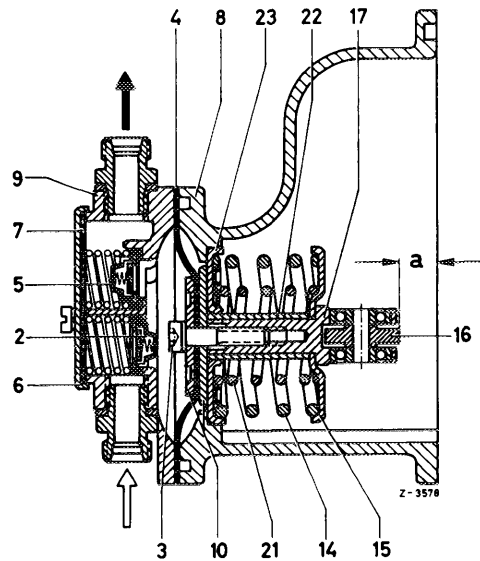

4 Unscrew closing plug for rocker arm shaft, pull shaft (11) out of pump housing by means of pliers and remove rocker arm (12) together with diaphragm rod (17).

5 Remove locking ring from bearing bolt (13) and pull bearing bolt out of rocker arm (12).

6 Remove guide bushing (22) from diaphragm rod (17), then remove lower spring retainer (15).

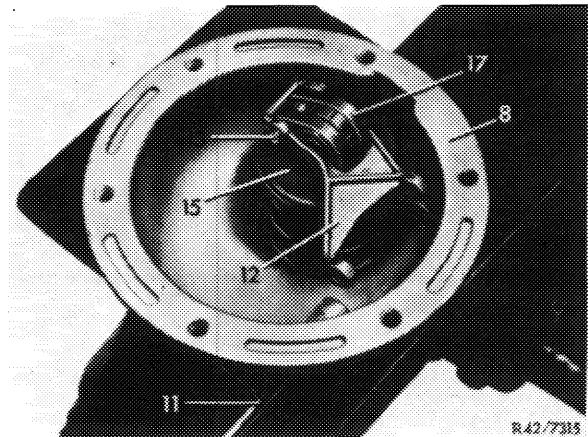

Assembly

7 Place lower spring retainer (15) on diaphragm rod (17) and press-on guide bushing (22).

8 Attach diaphragm rod (17) to rocker arm by means of bearing bolt (13) and insert locking rings.

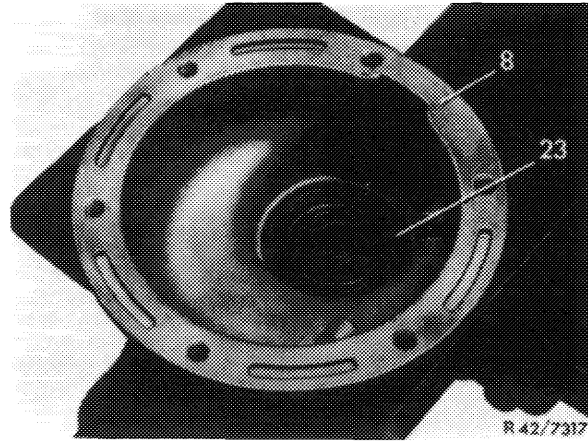

9 Place upper spring retainer (23) into pump housing and insert both compression springs (14 and 21). Introduce diaphragm rod with lower spring retainer (15) mounted into upper spring retainer, insert rocker arm and mount shaft (11). Screw-in closing plug for shaft with new gasket.

10 Insert vacuum pump into assembly plate and preload diaphragm rod (17) with screw spindle to dimension "a" = 26 mm. Make sure that the springs are correctly seated in spring retainers.

11 Install diaphragm (42–620).

12 Turn screw spindle on assembly plate back and remove vacuum pump from assembly plate.

