

A. Tandem main cylinder (not stepped)

Data

| | | |
|----------------------------------|------------------|----------|
| Dia. | Inches | 15/16 |
| | mm | 23.81 |
| Housing bore dia. | | 23.81 |
| | | 23.86 |
| Wear limit | | 23.92 |
| Permissible out-of-round of bore | | 0.03 |
| Piston dia. | | 23.77 |
| | | 23.74 |
| Wear limit | | 23.66 |
| Piston clearance | | 0.06—0.2 |
| Stroke | Push rod circuit | 13 |
| | floating circuit | 19 |

Lubricants

Silicon grease

Brake cylinder paste

| Tightening torque | Nm | (kpm) |
|-------------------|-----|-----------|
| Stop screw | 5—8 | (0.5—0.8) |

Note

For reconditioning use the following repair kits:

Teves tandem main cylinder 001 586 93 43

Bendix tandem main cylinder 001 586 55 43

Note that the Bendix tandem main cylinder sprayed blue may not be repaired.

Teves tandem main cylinder

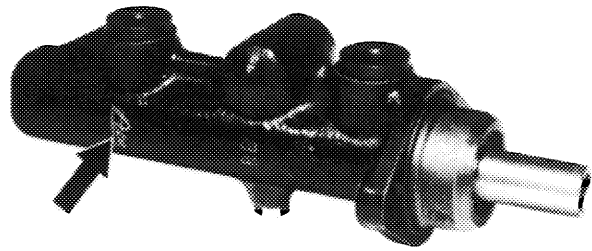

142-8633

Bendix tandem main cylinder

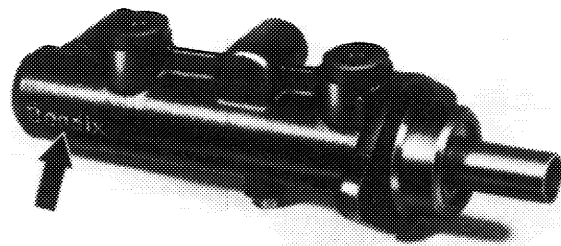

142-9512

- 1 Container plug
- 3 Piston (push rod circuit)
- 4 Stop washer
- 5 Locking ring
- 6 Vacuum seal
- 7 Intermediate ring
- 8 Stop washer
- 9 Filling disc
- 10 Primary sleeve
- 11 Supporting ring
- 12 Spring retainer
- 14 Connecting screw
- 15 Stop screw
- 17 Compression spring
- 18 Parting sleeve
- 19 Spring retainer
- 20 Piston (float circuit)
- 21 Compression spring
- 22 Housing
- A Leak hole
- B Filler hole
- C Compensating hole

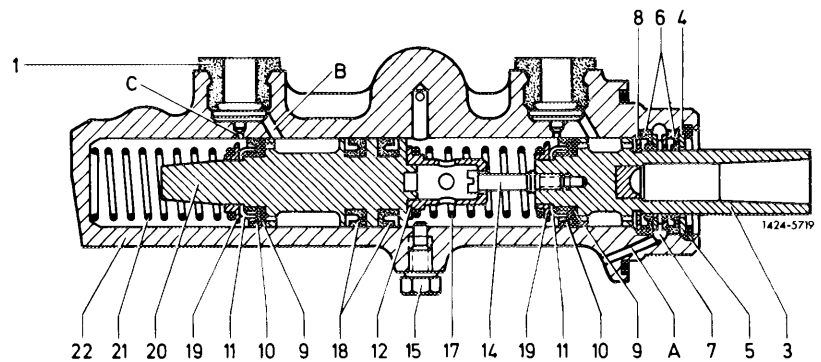

Disassembly

- 1 Pull expansion tank out of container plug of tandem main cylinder.
- 2 Push piston (3) slightly inwards by means of a mandrel, then unscrew stop screw (15) from housing and remove together with sealing ring.

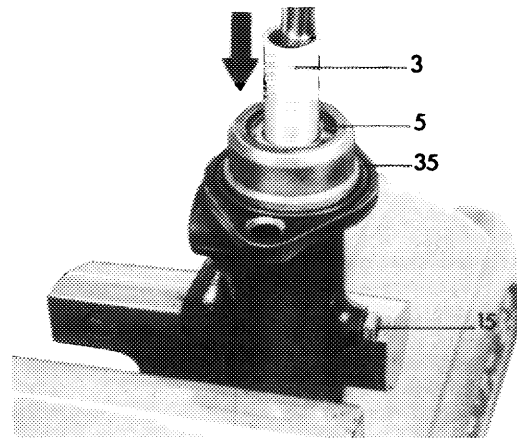

142-9459

3 Take locking ring (5) out of housing, then remove piston (3) from housing together with the two stop washers (4 and 8), the two vacuum seals (6) and the intermediate ring (7).

4 Remove complete piston for floating circuit by knocking housing slightly against a wooden board.

5 On Teves expansion tank, unscrew closing cover (25) and both end covers (29). Remove strainer (24), splash guide (23) and both contact inserts (27) including O-rings (31).

Note: The splash gird is installed only in expansion tank of 1st and 2nd version.

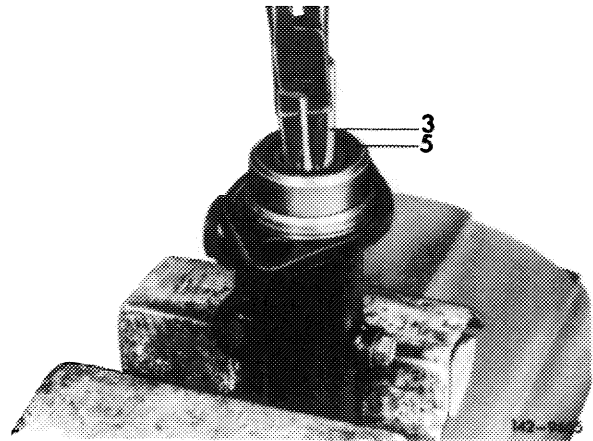

Teves expansion tank

- 23 Splash guard
- 24 Strainer
- 25 Closing cover
- 26 Expansion tank
- 27 Contact insert
- 28 O-ring
- 29 End cover
- 30 Float
- 31 O-ring

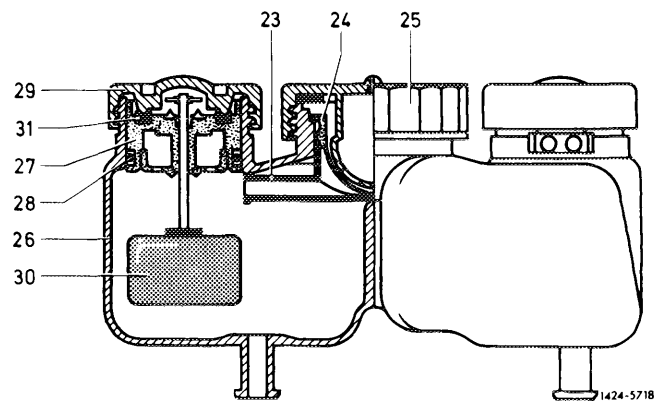

6 On Bendix expansion tank unscrew closing cover and remove strainer.

Note: The contact inserts of Bendix expansion tank cannot be removed.

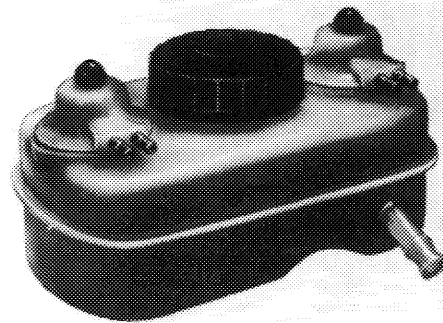

Bendix expansion tank

142-8636

Checkup

7 Clean all parts well with spirit of alcohol, make sure that all residue is flushed out of housing and expansion tank.

8 Check bore in housing for score marks and rust. Slightly rusted spots may be cleaned with polishing cloth.

Housings showing score marks and badly rusted spots should not be refinished.

Assembly

Bendix tandem main cylinder

- 9 Slightly coat bore of housing with brake cylinder paste.
- 10 Remove vacuum seals, stop washers, intermediate ring, O-ring and copper sealing ring from assembly sleeve.
- 11 Place assembly sleeve (040) on housing and slip complete piston package with a mandrel from sleeve (041) into housing.
- 12 Remove sleeve (041).

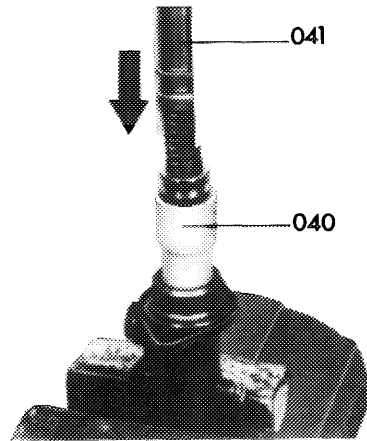

142-9463

- 13 Push piston (13) completely into housing by means of a mandrel, screw-in stop screw (15) with a new copper sealing ring and tighten to specified torque. Remove assembly sleeve.

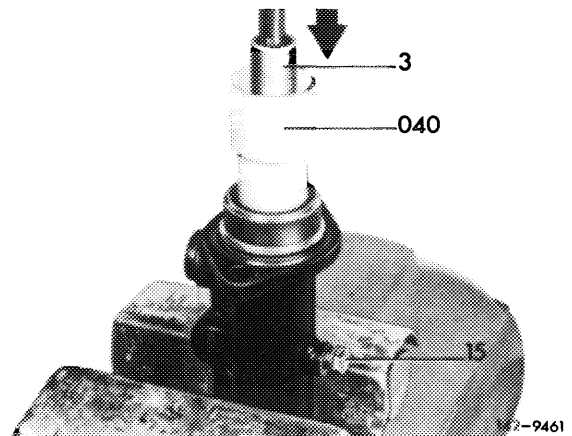

142-9461

- 14 Place stop washer (8) on piston (3).
- 15 Slightly grease stem of piston (3) with silicon grease.

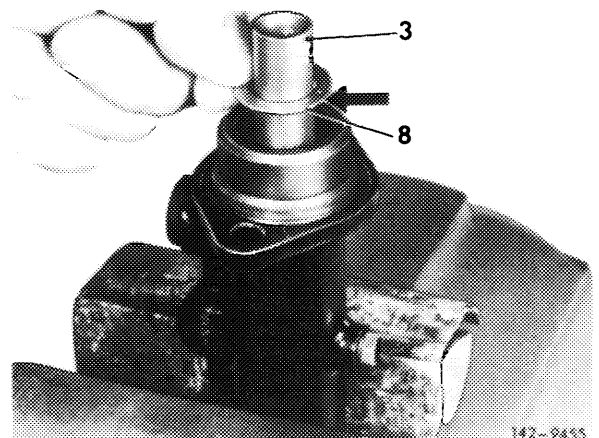

142-9455

16 Coat one vacuum seal (6) with silicon grease and place on shaft of piston with sealing lip facing piston. Then insert plastic foil (042) into housing bore and push vacuum seal into housing by means of assembly sleeve (040). Pull plastic foil out of housing and remove assembly sleeve.

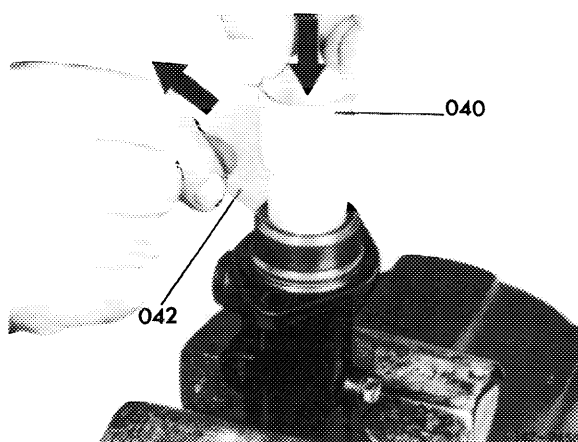
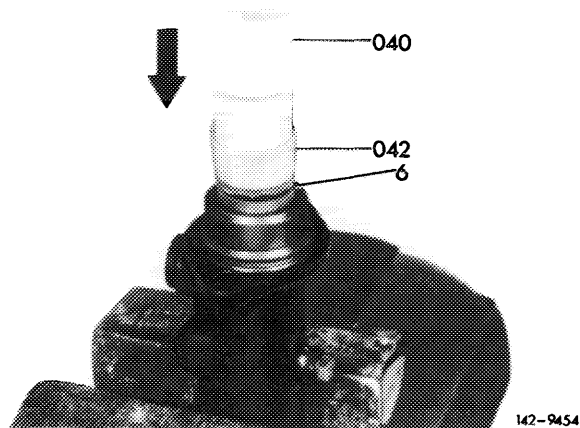
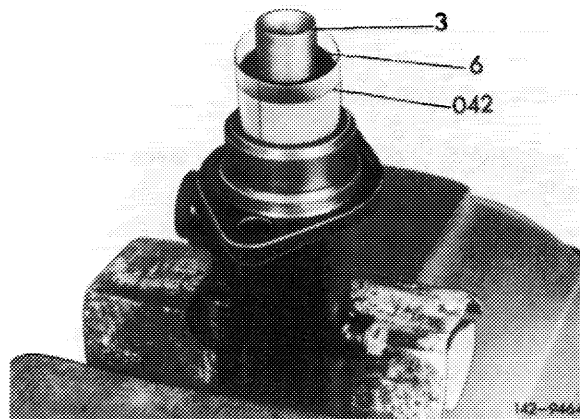

17 Insert intermediate ring (7) into housing, making sure that the bore in intermediate ring faces leak bore (A) in housing and push-in with assembly sleeve.

18 Install second vacuum seal (6) as shown in item 16.

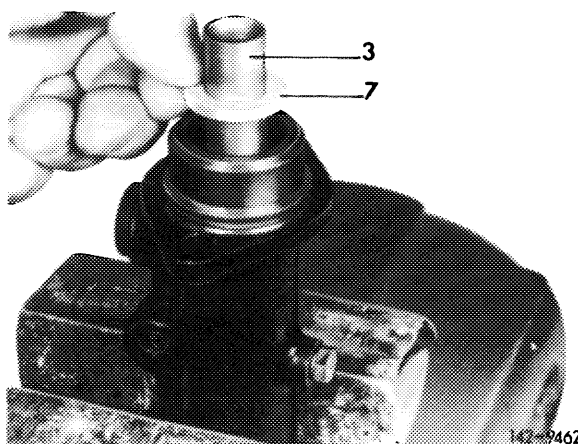

19 Place stop washer (8) on piston (3).

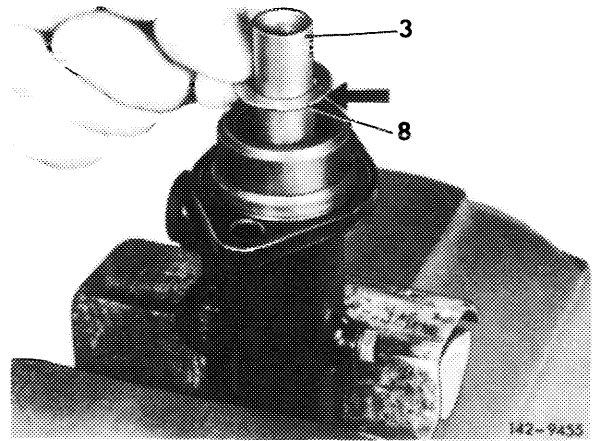

20 Insert locking ring (5), making sure that the ring is correctly seated in groove of housing.

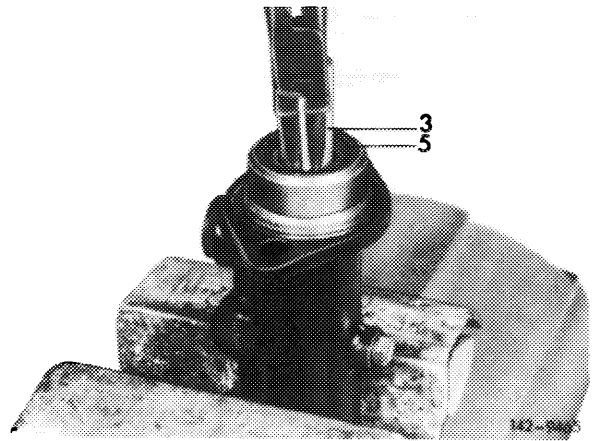

Teves tandem main cylinder

21 Slightly coat bore of housing with brake cylinder paste.

22 Remove vacuum seals, stop washers, intermediate ring, O-ring, copper sealing ring, locking ring and silicon grease from assembly sleeve.

23 Clamp housing slightly tilted with bore in downward direction. Push assembly sleeve (040) forward against end of sleeve (041) and insert into housing. Push complete piston package with a mandrel from sleeve (041) up to stop into housing. Screw-in stop screw with new copper sealing ring.

24 Remove sleeve (041) and assembly sleeve (040).

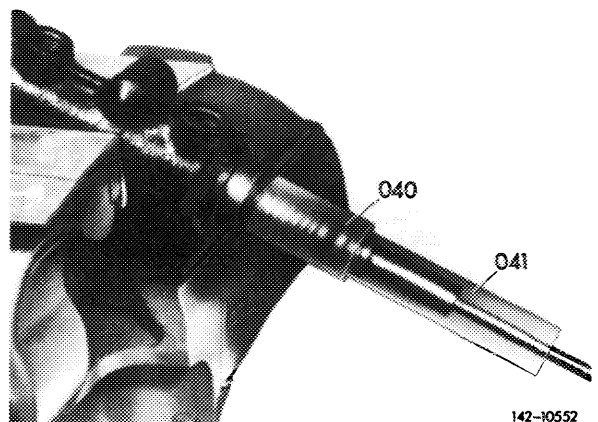

25 Clamp tandem main cylinder in such a manner that the piston stem is pointing upwards. Tighten stop screw (15) to specified torque.

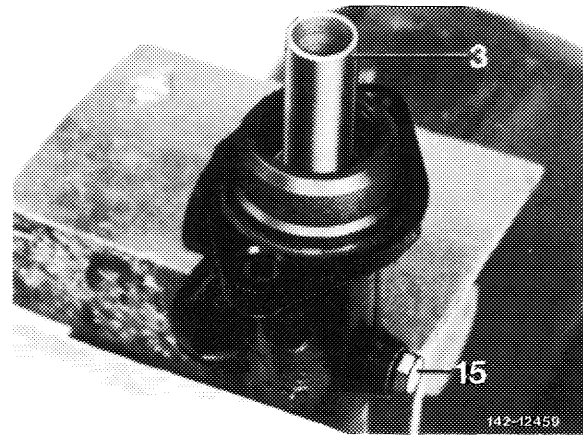

26 Place stop washer (8) on piston (3).

27 Slightly coat stem of piston (3) with silicon grease.

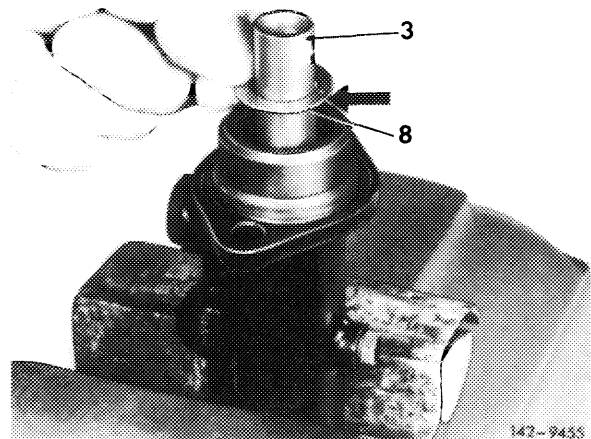

28 Adjust sleeve and assembly sleeve in such a manner that the end of sleeve (041) is in alignment with the inside edge of the smaller diameter of the assembly sleeve (040). Coat a vacuum seal with silicon grease, then place on stem of piston with sealing lip facing piston, hold in place and insert assembly sleeve (040) with inserted sleeve (041) over sleeve up to stop.

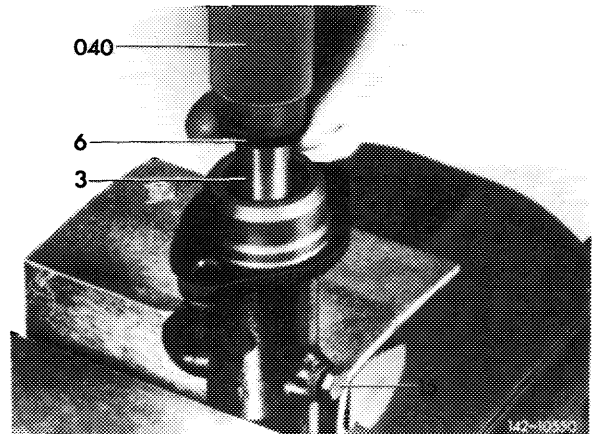

29 Slip both sleeves with vacuum seal into bore of housing and push seal downwards with sleeve (041). Pull up assembly sleeve (040) by height of sleeve, then remove both sleeves.

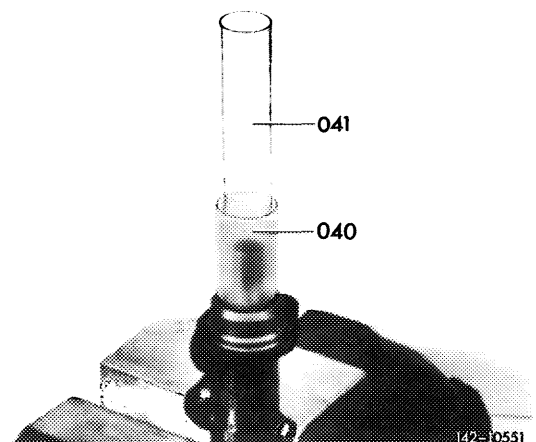

30 Insert intermediate ring (7) into housing, making sure that the bore in intermediate ring is pointing toward leak bore (A) in housing and push-in with sleeve (041).

31 Install second vacuum seal (6) as described in item 28 and 29.

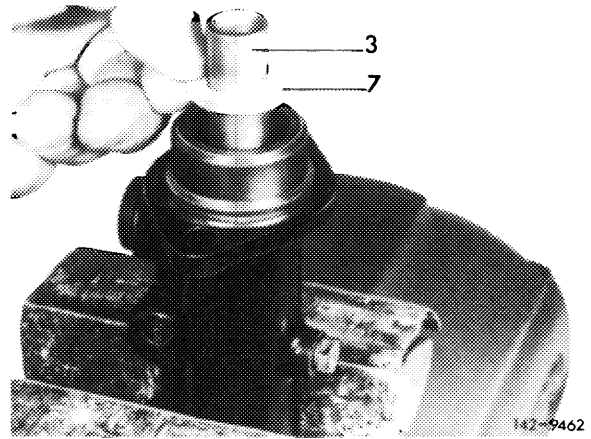

32 Place stop washer (8) on piston (3).

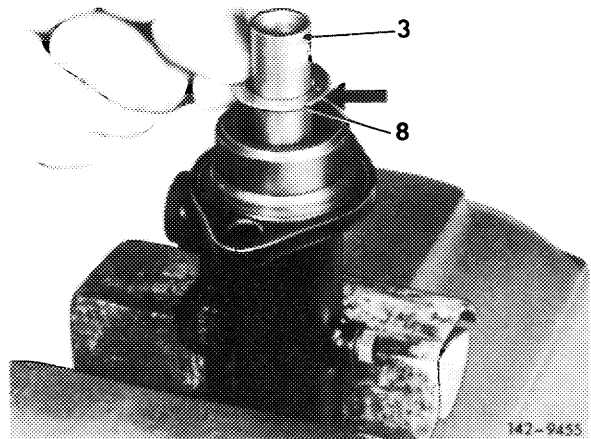

33 Insert locking ring (5), making sure that the ring is correctly seated in groove of housing.

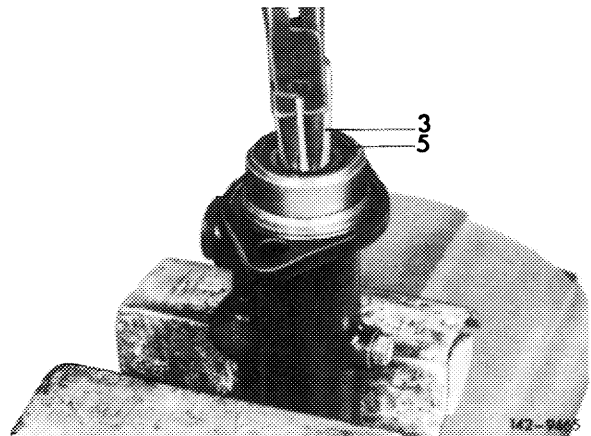

Mounting expansion tank

34 Coat container plug (1) lightly with brake cylinder paste and push into housing.

35 Insert expansion tank (26) first with one pipe connection into housing, turn by 180° and push second pipe connection into housing.

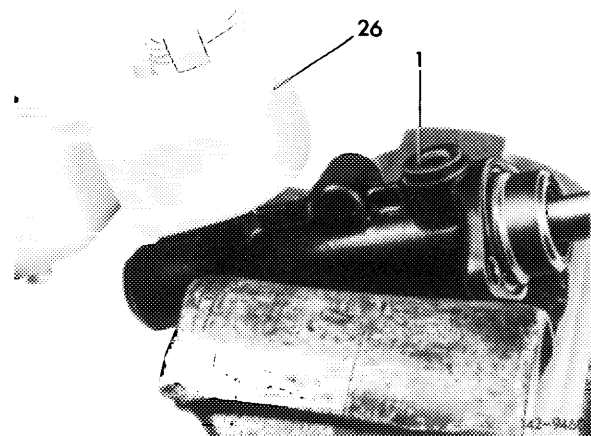

Pay attention to perfect seating (refer to arrow).

36 On Bendix expansion tank, insert strainer into container and screw-on closing cover.

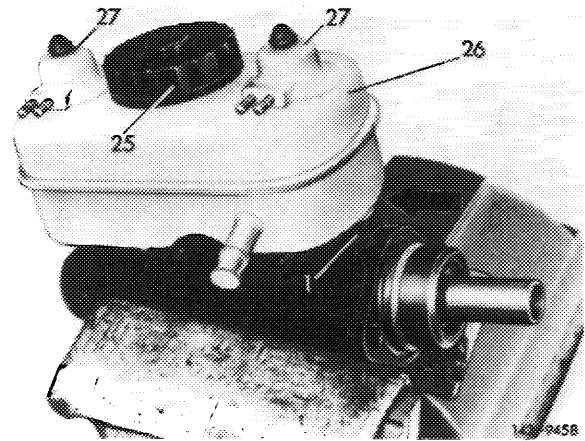

37 On Teves expansion tank, insert both contact inserts (27) with new O-rings (28) into expansion tank. Mount O-rings (31) and screw-on end cover.

Teves expansion tank

- | | |
|-------------------|--------------|
| 23 Splash guard | 28 O-ring |
| 24 Strainer | 29 End cover |
| 25 Closing cover | 30 Float |
| 26 Expansion tank | 31 O-ring |
| 27 Contact insert | |

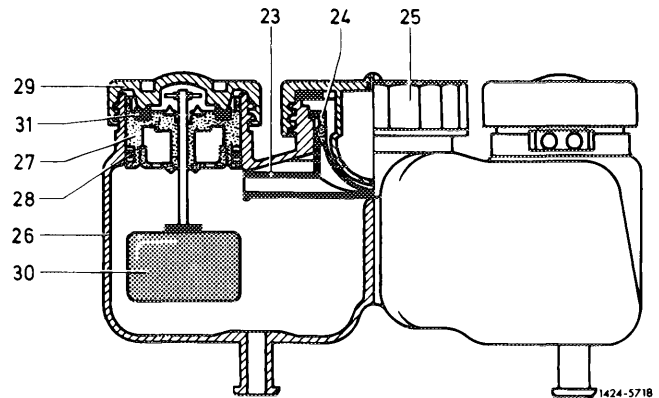

Note: The Teves expansion tank is provided that the following contact inserts:

Expansion tank 1st and 2nd version

Production up to spring 1972:

Both chambers with contact inserts 58 mm high and metal float rod.

Production from spring 1972 to spring 1974:

Front axle brake circuit with contact insert 58 mm high and rear axle brake circuit with insert 42 mm high and metal float rod.

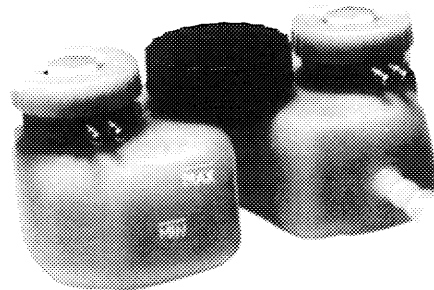

Teves expansion tank 1st version

142-8653

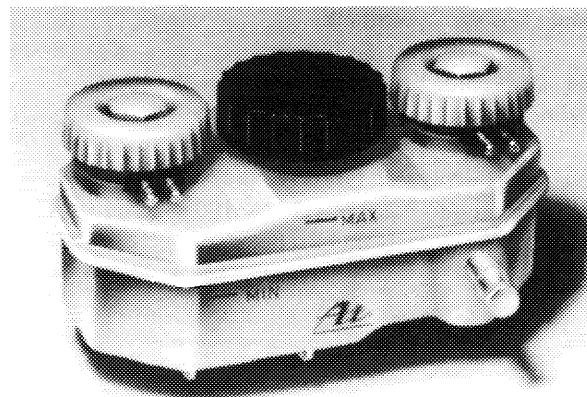

Teves expansion tank 2nd version

142-9514

Expansion tank 3rd version

Production starting spring 1974 (three-chamber expansion tank):

Both chambers with contact inserts 58 mm high and metal or plastic float rod.

No splash guard may be installed in this expansion tank.

Teves expansion tank 3rd version

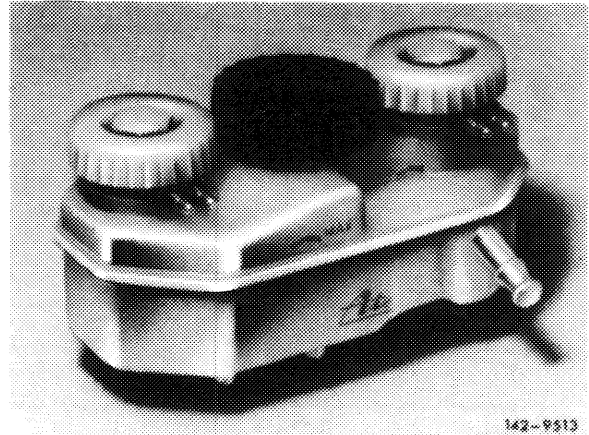

38 Insert splash guard (23) and strainer into tank and screw-on closing cover.

39 Place O-ring (35) into flange of housing.

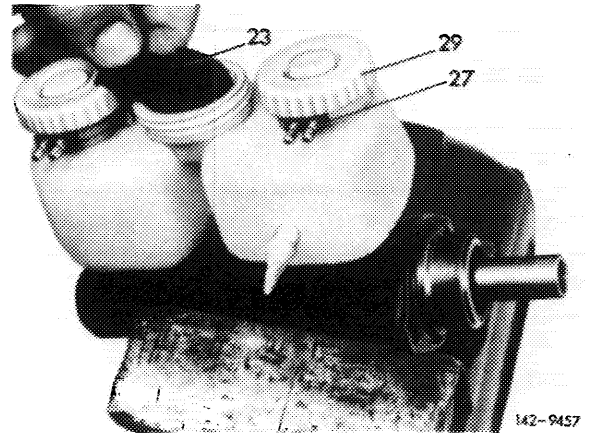

B. Tandem main cylinder (stepped only USA version – model year 1976)

Data

| | | Push rod circuit | Floating circuit |
|----------------------------------|--------|------------------|------------------|
| Dia. | Inches | 15/16 | 3/4 |
| | mm | 23.81 | 19.05 |
| Housing bore dia. | | <u>23.81</u> | <u>19.05</u> |
| | | 23.86 | 19.10 |
| Wear limit | | 23.92 | 19.16 |
| Permissible out-of-round of bore | | 0.03 | |
| Piston dia. | | <u>23.77</u> | <u>19.01</u> |
| | | 23.74 | 18.97 |
| Wear limit | | 23.66 | 18.90 |
| Piston clearance | | 0.06–0.26 | |
| Stroke | | 15 | 17 |

Lubricants

Silicon grease

Brake cylinder paste

Tightening torques

| | Nm | (kpm) |
|--------------|-------|-----------|
| Stop screw | 5–8 | (0.5–0.8) |
| Closing plug | 15–30 | (1.5–3) |
| Switch | 15–20 | (1.5–2) |

Self-made tool

Assembly pin (material: steel) refer to illustration Fig. 17, note

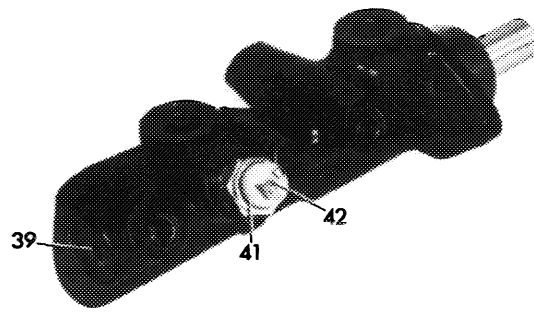

142-10793

Stepped tandem main cylinder with pressure difference warning indicator

- 3 Piston (push rod circuit)
- 20 Piston (floating circuit)
- 35 Control piston
- 36 Ring collar
- 37 Spring
- 38 Spring retainer
- 39 Screw
- 40 Sealing ring
- 41 Switch
- 42 Release pin

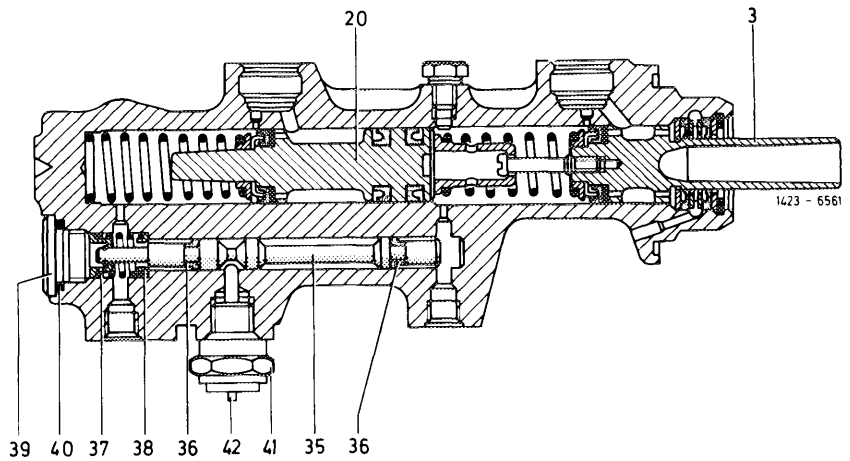

Disassembly

- 1 Pull expansion tank and container plug from tandem main cylinder.
- 2 Push piston (3) slightly inwards by means of a mandrel, then unscrew stop screw (15) from housing and remove together with sealing ring.
- 3 Take locking ring (5) out of housing. Then remove piston (3) together with the two stop washers (4 and 8), the two vacuum seals (6) and the intermediate ring (7) from housing.
- 4 Remove complete piston for floating circuit by knocking housing lightly against a wooden board.
- 5 Unscrew closing plug (39) and knock out control piston (35) as described under item 4.

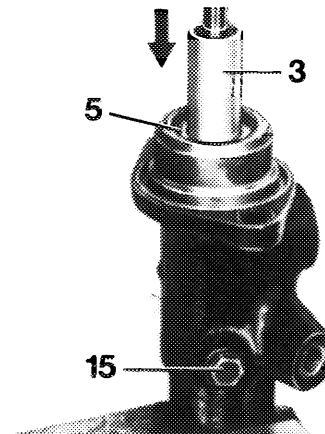

142-11753

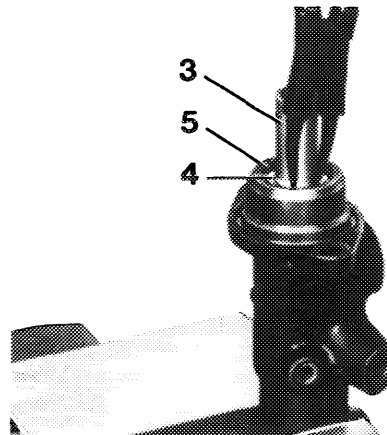

142-11752

6 Unscrew closing cover (25) and remove strainer.

Note: The contact insert (30) cannot be removed.

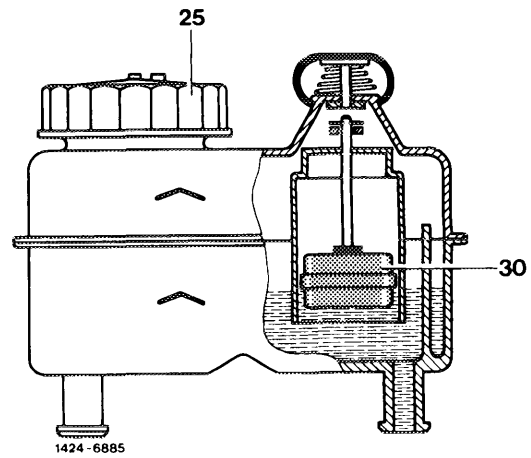

Checkup

7 Clean all parts well with spirit of alcohol, make sure that all residue is flushed out of housing and expansion tank.

8 Check bore in housing for score marks and rust. Slightly rusted spots may be cleaned with polishing cloth.

Housing showing score marks and badly rusted spots should not be refinished.

Assembly

9 Slightly coat bore of housing with brake cylinder paste.

10 Remove vacuum seals, stop washers, intermediate ring, O-ring and copper sealing ring from assembly sleeve.

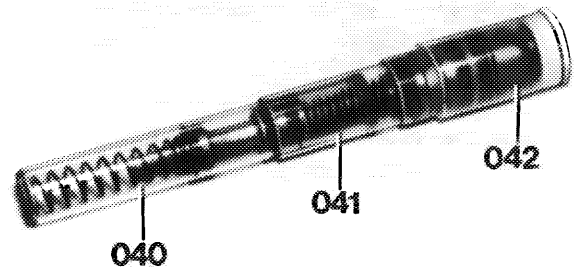

142-12081

11 Clamp housing slightly tilted with bore in downward direction. Remove assembly sleeve (040) including floating piston (19.05 dia.) from assembly sleeve (041) for push rod piston (23.81 dia.). Place assembly sleeve (041) into housing and slide piston into housing up to stop by means of a mandrel.

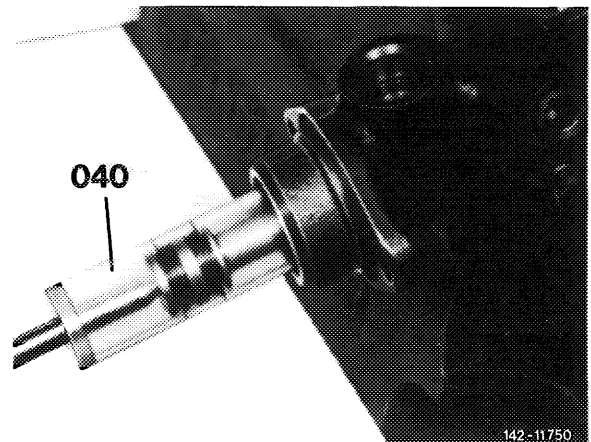

12 Hold piston in place with mandrel, pull assembly sleeve (040) out until the stop screw (15) can be screwed in with a new copper sealing ring.

Tighten stop screw (15) to 5–8 Nm (0.5–0.8 kpm).

13 Remove assembly sleeve (040).

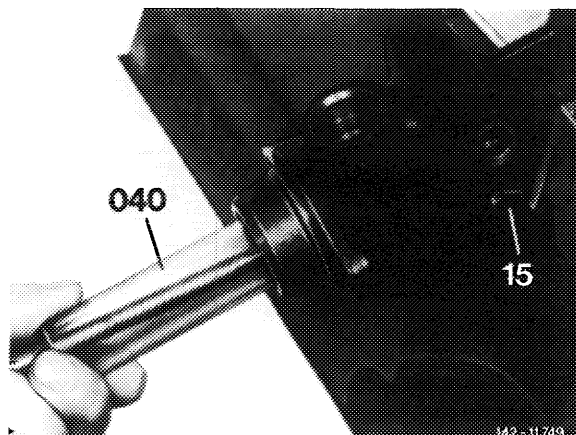

14 Clamp tandem main cylinder in such a manner that cylinder bore is pointing upwards.

15 Remove assembly sleeve (041) including push rod piston (23.81 dia.) from assembly sleeve (042) for secondary seal. Insert assembly sleeve (041) into housing and slip piston (3) into housing by means of a mandrel.

16 Remove assembly sleeve (041).

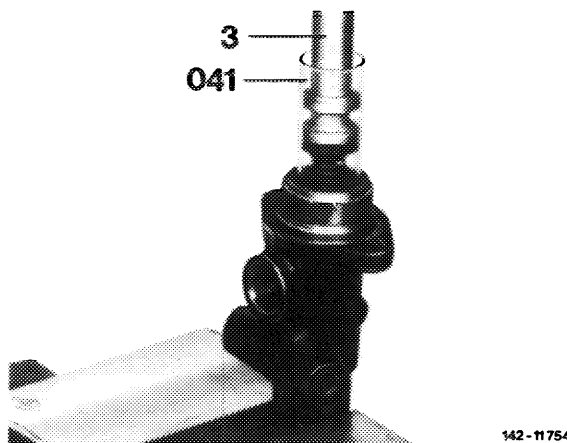

17 Push piston (3) in until the second collar of the push rod piston is behind the filler hole. Then insert assembly pin (045) into filler hole up to stop. Make sure that the push rod piston is not damaged.

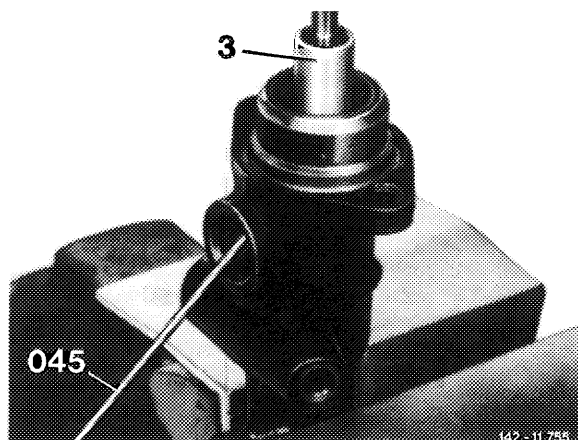

Note: The assembly pin (045) serves as a stop and must be self-made from steel according to the dimension shown in illustration.

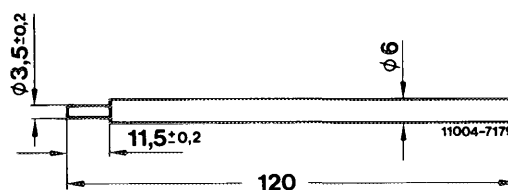

18 Place stop washer (8) on piston (3).

19 Slightly coat stem of piston (3) with silicon grease.

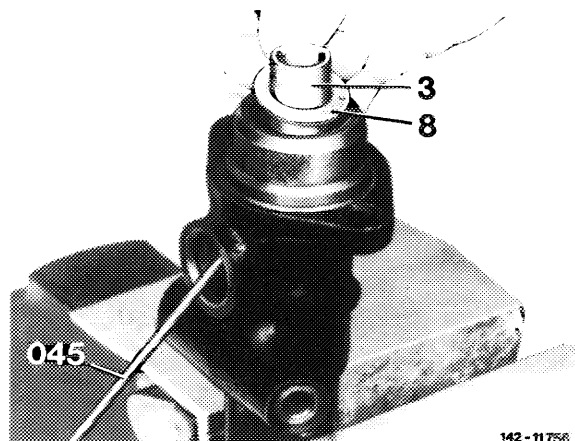

142-11756

20 Coat a vacuum seal (6) with silicon grease, then mount on stem of piston with sealing lip facing piston, hold in place and insert assembly sleeve (042) over sleeve up to stop.

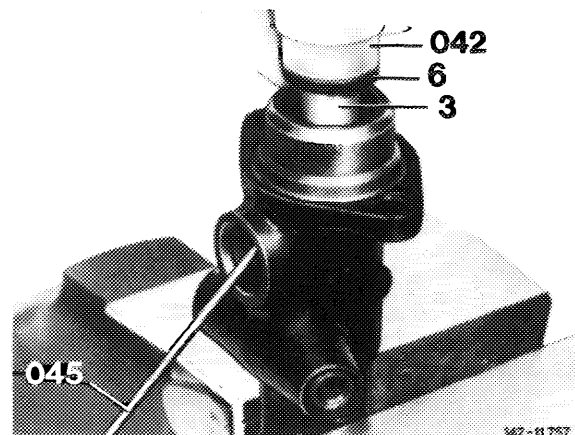

142-11757

21 Slip assembly sleeve (042) with vacuum sleeve (6) into housing bore. Push vacuum seal down with blunt portion of assembly sleeve (040). Pull up assembly sleeve (042) first by height of sleeve, then remove both sleeves.

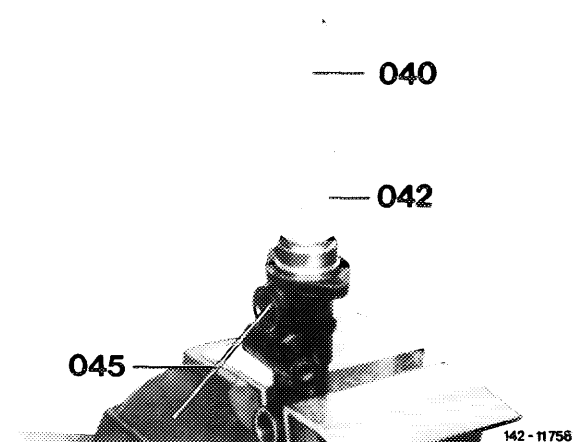

142-11758

22 Insert intermediate ring (7) into housing, making sure that the bore in intermediate ring faces leak hole (A) in housing and push inwards with sleeve (040).

23 Install second vacuum seal (6) as described under item 20 and 21.

24 Mount stop washer (8) as described under item 18.

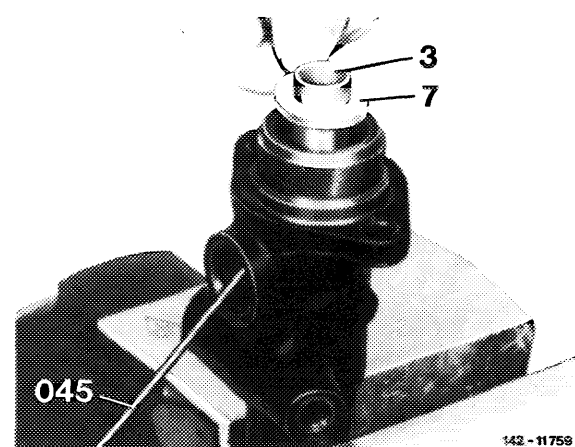

142-11759

25 Insert locking ring (5), making sure that the ring is correctly seated in groove of housing.

Then push piston downward and pull out assembly pin.

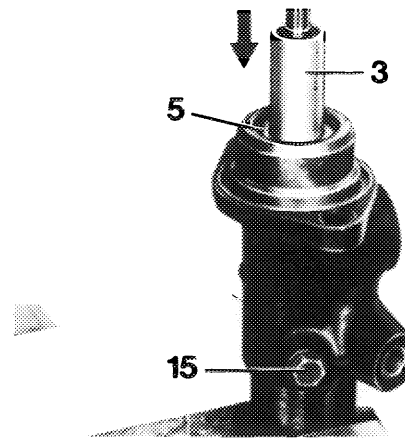

142 - 11 753

26 Slip control piston (35) into housing, make sure that ring collars (36) are not damaged.

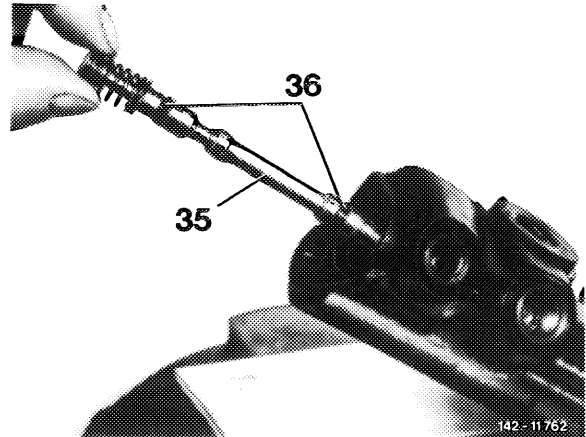

142 - 11 762

27 Screw-in closing plug (39) and tighten to 15–30 Nm (1.5–3 kpm).

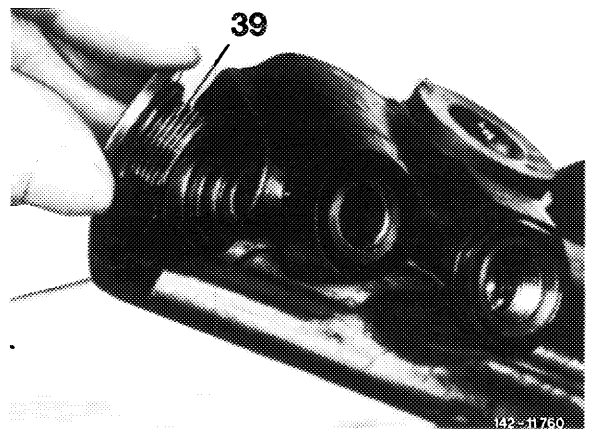

142 - 11 760

28 Screw switch (41) into housing and tighten to 15–20 Nm (1.5–2 kpm).

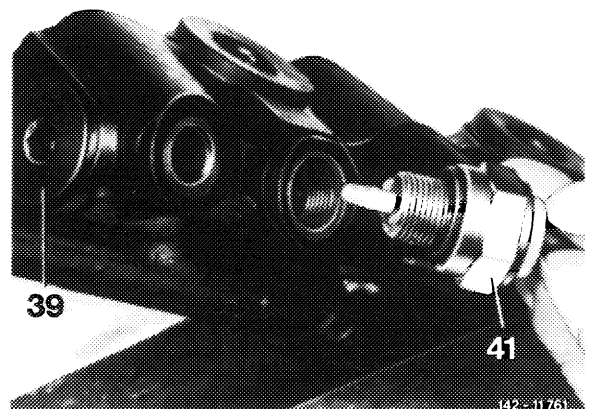

142 - 11 761

Mounting expansion tank

29 Insert strainer into container and screw-on closing cover.

30 Slightly coat container plug (1) with brake cylinder paste and push into housing.

31 Insert expansion tank (26) first with one pipe connection into housing, turn by 180° and push second pipe connection into housing. Watch out for perfect seat.

