

A. Rear axle center piece with lateral bearing caps

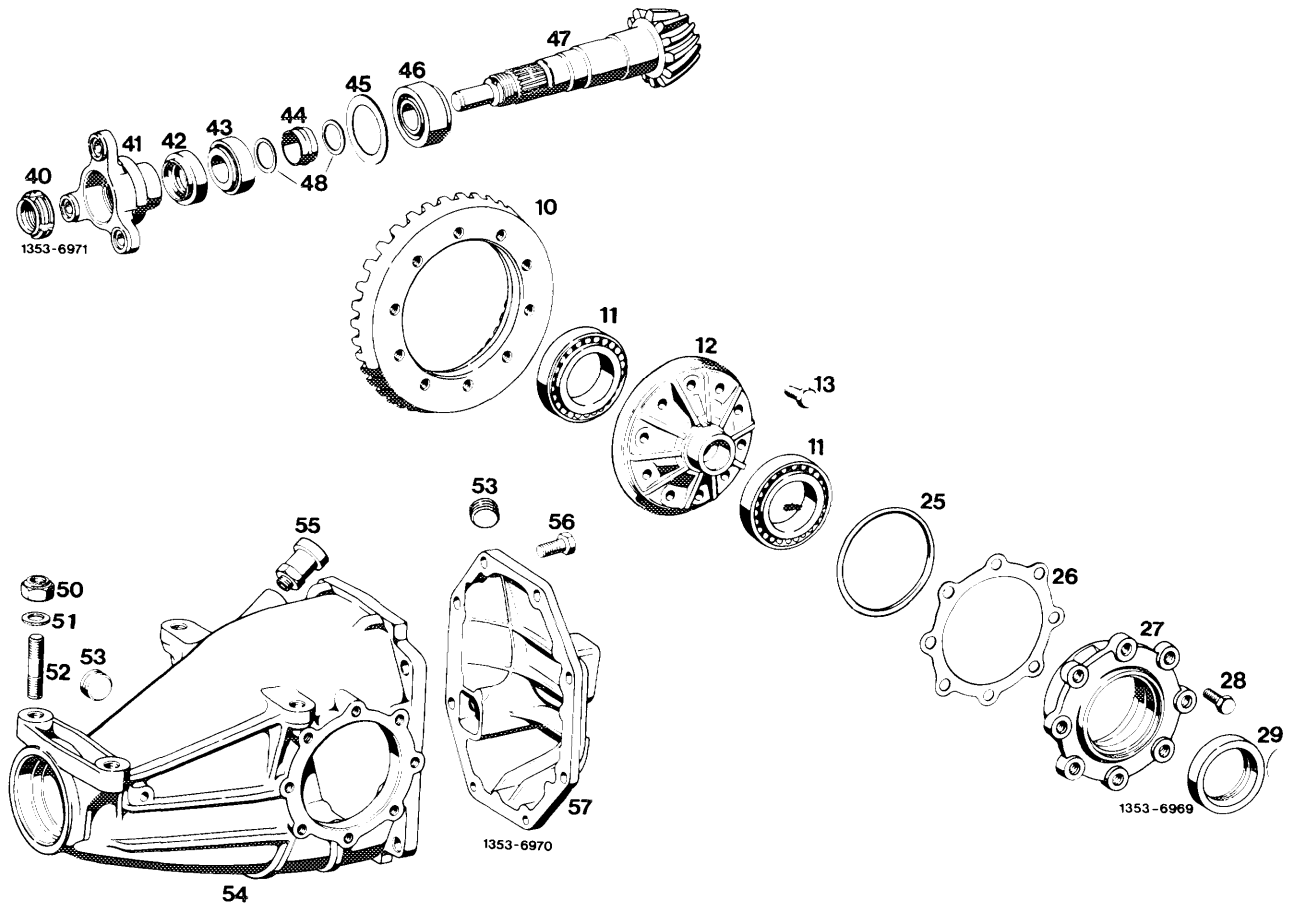

10	Ring gear	Check for damage and wear For assembly, heat to 60–70 °C
11	Tapered roller bearing (differential)	Check for damage and wear
12	Differential housing	Check for damage
13	Hex. head screw normal or self-locking.	Renew, pay attention to tightening torque and length, refer to table
25	Sealing ring	Renew
26	Compensating washer	
27	Bearing cap	Check for damage
28	Hex. head screw	Tightening torque 20 Nm
29	Radial sealing ring	Renew
40	Slot nut or double hex. collar nut	Renew, secure by peening collar
41	Universal flange	Check, renew, if vertical runout exceeds 0.06 mm after resetting several times
42	Radial sealing ring	Renew
43	Small tapered roller bearing (drive pinion)	Check for damage and wear
44	Spacing sleeve	Renew

45	Compensating washer	
46	Large tapered roller bearing (drive pinion)	Check for damage and wear
47	Drive pinion	Pay attention to mating no., check for damage and wear. Refer to note: A item 28
48	Washer	Renew
50	Self-locking nut	Renew, tightening torque 100 Nm
51	Washer	
52	Stud	Check for damage, tightening torque 50 Nm
53	Closing plug	
54	Rear axle housing.	Check for damage
55	Breather	Renew
56	Hex. screw	Tightening torque 45 Nm
57	End cover	Check for damage, clean parting surface and coat with sealing compound

Oil types and capacities

Standard differential	Hypoid gear oil SAE 90 refer to specifications for service products page 235	
Differential with restricted slip (positive traction) (name plate on rear axle housing)	Special Hypoid gear oil refer to specifications for service products page 235.3	
Capacity	large center piece ¹⁾	1.3 litres
	small center piece ¹⁾	1.0 litre ²⁾

¹⁾ Refer to installation survey rear axle center piece 35–500

²⁾ On models 114 and 115 with rear rubber bearing of rear axle 1st version (cast iron end cover)
the oil capacity amounts to 1.15 liter.

Gear wheel (rotor) for rpm sensor on vehicles with ABS

Part number	Ratio	Number of teeth
123 353 01 85	4.08	23
123 353 02 85	3.92	24
123 353 03 85	3.69	26
123 353 04 85	3.58/3.54	27
123 353 05 85	3.46	28
126 353 00 85	3.27	29
126 353 01 85	3.06/3.07	31
126 353 03 85	2.82	34
126 353 04 85	2.72	35
126 353 06 85	2.47	39
126 353 05 85	2.24	43

Compensating washers for adjusting backlash and spread

Thickness	large center piece ¹⁾	0,9 to 1.4
	small center piece ¹⁾	0.6 to 1.9
Steps		0.05 to 0.05

Note: If required, grind one compensating washer to required thickness.

Adjusting values of gear assembly

Backlash of gear assembly		0.08–0.14 mm
Adjustment of tapered roller bearings for differential: Tapered roller bearings are provided with the required preload by widening (spreading) rear axle housing by	large center piece ¹⁾	0.15–0.20 mm
	small center piece ¹⁾	0.10–0.15 mm
Permissible tolerance of adjusting dimension "A" of drive pinion		+ 0.01 –0.02
Adjustment of tapered roller bearing of drive pinion by measuring friction torque when rotating drive pinion with friction torque wrench ²⁾	new tapered roller bearing	120–140 Ncm
	used tapered roller bearing	50–100 Ncm

¹⁾ Refer to installation survey rear axle center piece 35–500.

²⁾ For correct adjustment of tapered roller bearings tighten slot nut or double hex. collar nut on universal flange until the specified friction torque is attained when rotating drive pinion. For checking friction torque when rotating drive pinion, the differential with ring gear should not be installed.

Compensating washers for adjusting drive pinion

Thickness	large center piece	1.5 to 2.4
	small center piece	1.5 to 1.8
Steps		0.05 to 0.05

Note: If required, grind one compensating washer to required thickness.

Fastening screws for ring gear

Center piece version	Flange thickness of differential housing	Length of hex. screws	Part number	
Large	10	22	116 990 02 01	
	8	20	standard	126 990 01 01
			self-locking	126 990 07 01
	10	20	128 990 00 01	
Small	8	18	standard	123 990 16 01 (replaced)
			self-locking	123 990 30 01

Universal flange on drive pinion

Dia. of running surface for radial sealing ring on universal flange	when new	$\frac{40.00}{39.84}$
	minimum dia. for repairs ¹⁾	39.6
Running surface of universal flange		without thread
Permissible vertical runout of sealing surface of universal flange		0.06





¹⁾ Refinish running surface for seal in an emergency only.





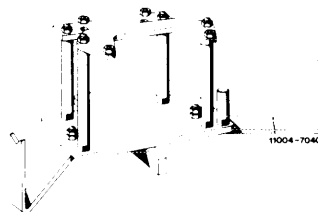

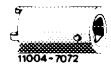
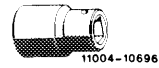
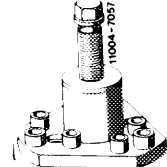
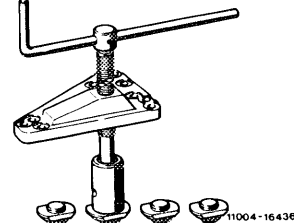
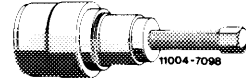
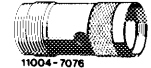
Compensating washer between inner synchromesh joint and differential housing

Spacing ring	Thickness	from 2.6 to 3.4
	Steps	from 0.1 to 0.1

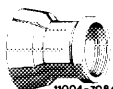
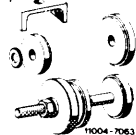
Tightening torques		Nm	
Hex. screws for fastening rear axle end cover to rear axle housing		45	
Fastening screws for ring gear	Small center piece	standard	80
		self-locking	100
	Large center piece	standard	120
		self-locking	140
Studs in rear axle housing		50	
Hex. screws for bearing caps on rear axle housing		20	

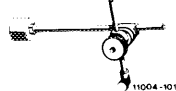
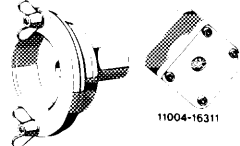
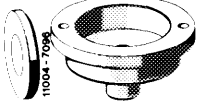
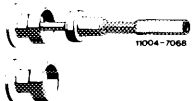
Special tool

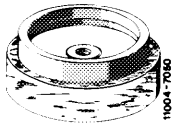
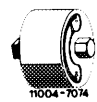
Assembly stand for rear axle center piece		116 589 00 59 00
Holding wrench for universal flange		116 589 10 07 00
Slot nut socket 3/4" square for slot nut on universal flange		115 589 01 07 00
Socket 30 mm double hex. 3/4" square for double hex. collar nut on universal flange		126 589 02 09 00
Puller for universal flange on drive pinion		116 589 19 33 00
Installer and remover for pinion		201 589 02 43 00
Puller for tapered roller bearing inner races (basic tool)		001 589 36 33 00
Extension for puller 001 589 36 33 00		000 589 35 34 00
Thrust piece for radial sealing ring on drive pinion		124 589 02 15 00

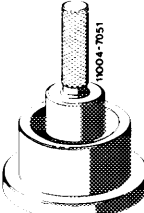
Collet for puller 001 589 36 33 00 for tapered roller bearing inner race	small center piece large center piece	 11004-7084	000 589 33 34 00 000 589 34 34 00
Installer for tapered roller bearing outer races		 11004-7063	116 589 11 61 00
Measuring plate for pinion height with bearing		 11004-11138	601 589 00 23 00
Dial gauge holder for measuring plate 601 589 00 23 00		 11004-10150	363 589 02 21 00
Measuring device for pinion bearing height in rear axle housing	small center piece	 11004-16311	123 589 01 21 00
	large center piece	 11004-7096	116 589 01 21 00
Measuring device for pinion bearing		 11004-7066	116 589 07 21 00
Dial gauge holder		 11004-7073	111 589 08 23 00
Adjusting gauge for adjusting pinion		 11004-7086	115 589 05 21 00
Torque measuring tool 30–600 Ncm 1/2" square		 11004-7074	001 589 49 21 00
Connection 3/4" square head to 1/2" square socket		 11004-6362	100 589 02 59 00
Removing tool for removing tapered roller bearing outer race and radial sealing ring from bearing cap	small center piece	 11004-7051	115 589 00 35 00

Removing tool for removing tapered roller bearing outer race from bearing cap
 large center piece

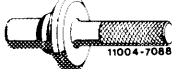
 11004-708
 116 589 00 35 00

Installing mandrel for radial sealing ring with 65 mm OD

 11004-7088
 116 589 05 43 00

Installing mandrel for radial sealing ring with 81 mm OD

 11004-7093
 116 589 10 15 00

Measuring bracket for measuring inclination

 11004-10278
 126 589 08 21 00

Backlash gauge

 11004-16312
 201 589 03 21 00

Assembly mandrel for inner race of tapered roller bearing

 11004-7085
 115 589 04 61 00

Puller for tapered roller bearing

 11004-10279
 123 589 08 33 00

Puller for pulling gear wheel on drive pinion of vehicles with ABS

 11004-7201
 000 589 88 33 00

Conventional tools

Two-arm puller
 e.g. made by Nexus, D-5630 Remscheid
 order no. 100 size 2

Self-made tools

Installing sleeve for tapered roller bearing on drive pinion

A = Small drive pinion
 B = Large drive pinion

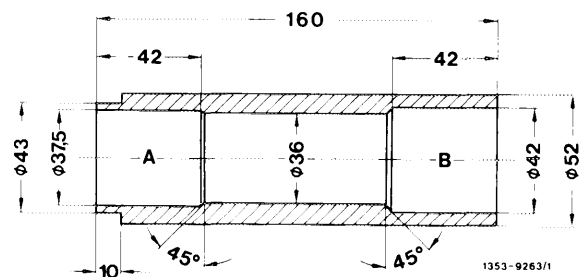

Installing sleeve for gear wheel on drive pinion of vehicles with ABS

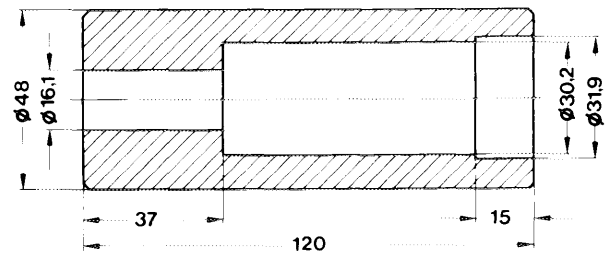

1354-9282

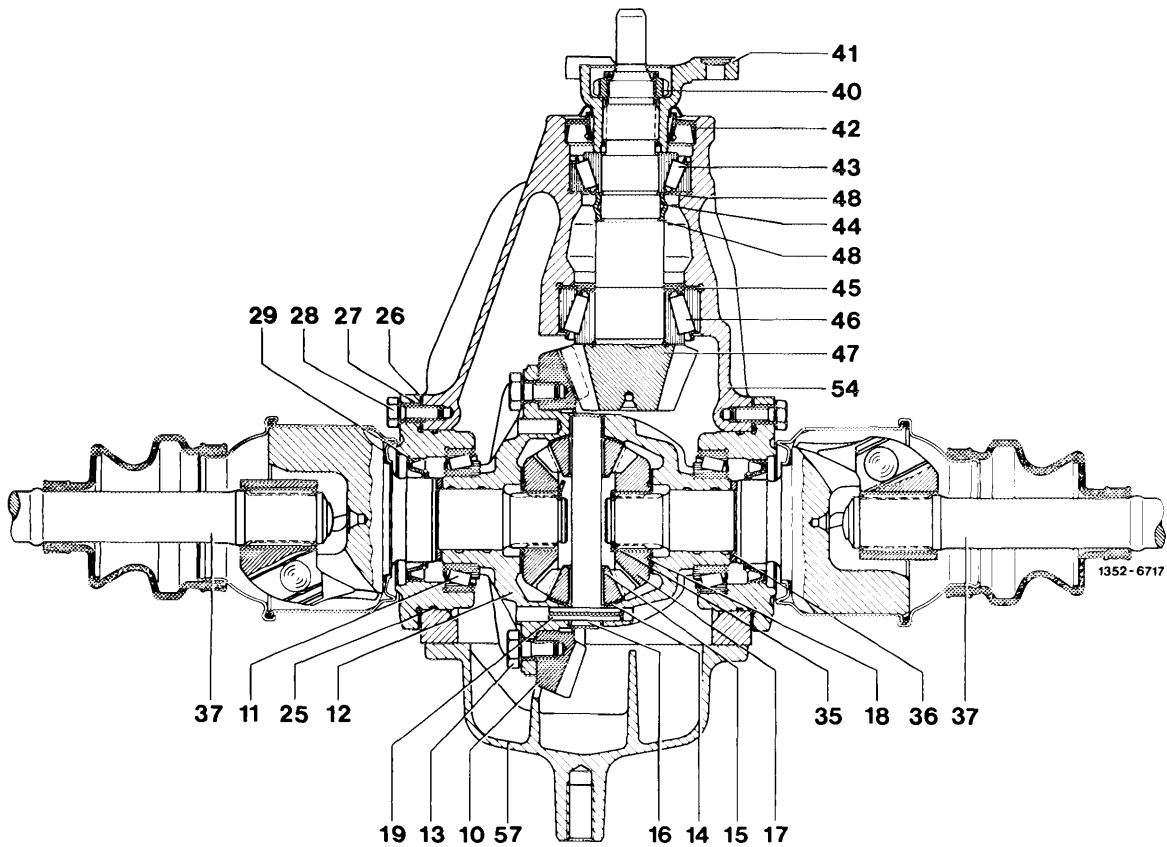

- | | | | |
|------------------------------|------------------------|---|---------------------------------|
| 10 Ring gear | 17 Side gear | 29 Radial sealing ring | 43 Small tapered roller bearing |
| 11 Tapered roller bearing | 18 Thrust washer | 35 Locking ring | 44 Spacing sleeve |
| 12 Differential housing | 19 Clamping sleeve | 36 Compensating washer | 45 Compensating washer |
| 13 Hex bolt | 25 Sealing ring | 37 Rear axle shaft complete | 46 Large tapered roller bearing |
| 14 Ball washer | 26 Compensating washer | 40 Crush collar nut or double hex. collar nut | 47 Drive pinion |
| 15 Differential pinion | 27 Bearing cap | 41 Universal flange | 48 Thrust washer |
| 16 Differential pinion shaft | 28 Hex bolt | 42 Radial sealing ring | 54 Rear axle housing |
| | | | 57 Rear axle end cover |

Disassembly

Removing differential together with ring gear

- 1 Remove rear axle center piece with rear axle shafts (35-520).
- 2 Clamp rear axle center piece with rear axle shafts on assembly stand (1) and support rear axle shafts. Drain oil from rear axle housing.

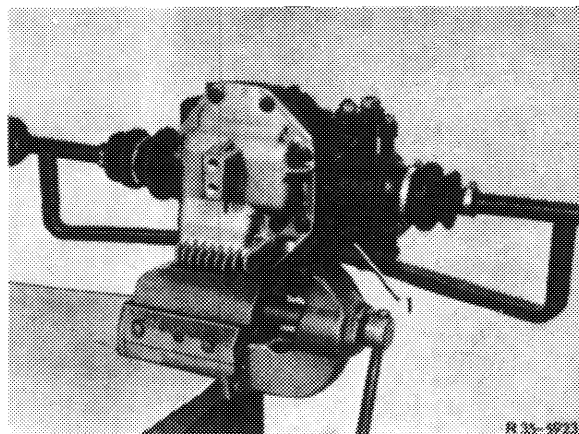

R 35-5923

3 Unscrew end cover (4) from rear axle housing.

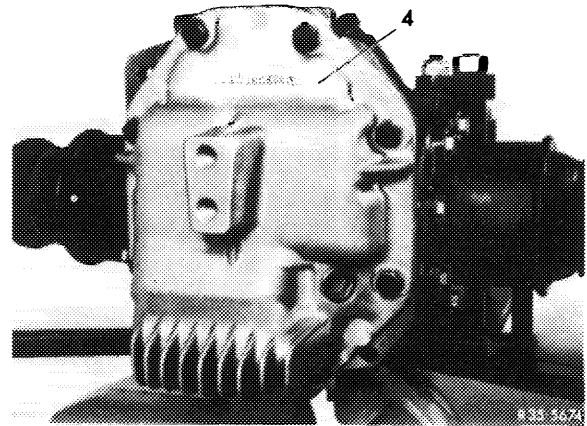

4 Pull off locking rings (26) between inner synchromesh joints and side gears by means of pliers (1) or a hook and remove from housing.

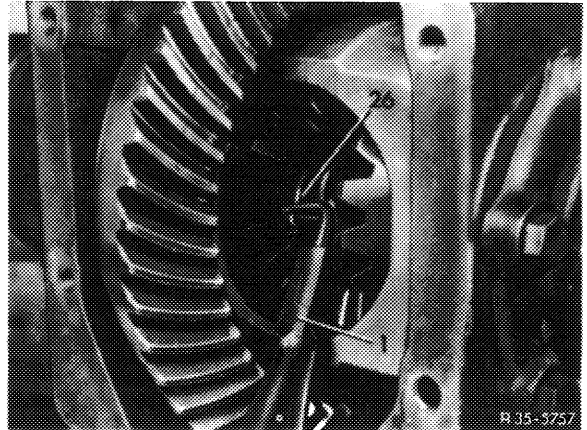

5 Pull rear axle shafts out of side gears and remove together with spacing rings (11).

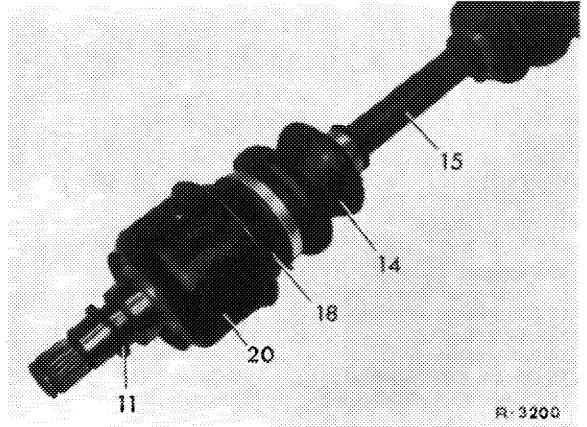

6 Remove lateral bearing caps (24).

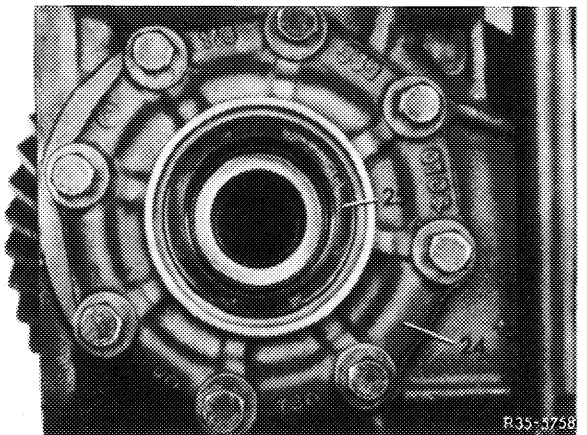

7 Pull off sealing rings (22). Remove compensating washers (23) for adjusting backlash or spread dimension (widening) and mark together with bearing caps (for lefthand and righthand side).

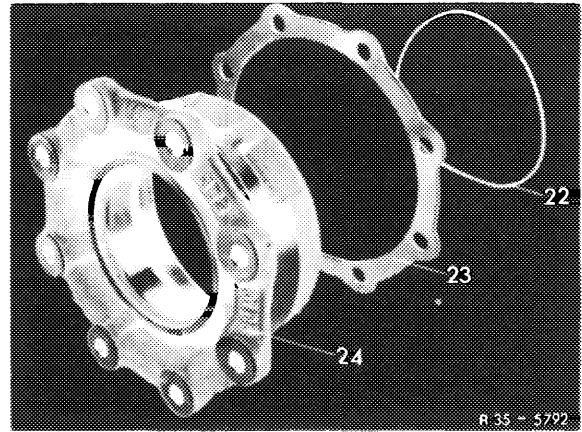

With small rear axle center piece

8 Press radial sealing ring and tapered roller bearing outer race together out of bearing cap by means of removing tool (1 and 2).

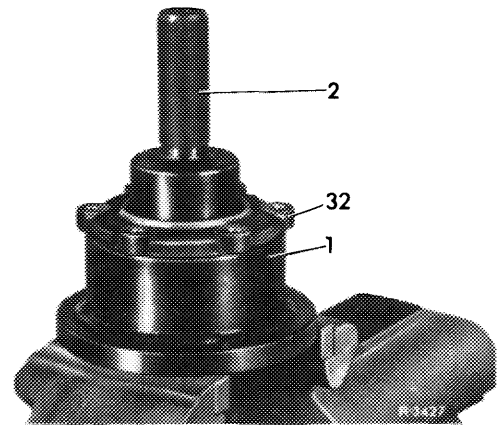

With large rear axle center piece

9 Force radial sealing ring out of bearing cap by means of removing tool (1).

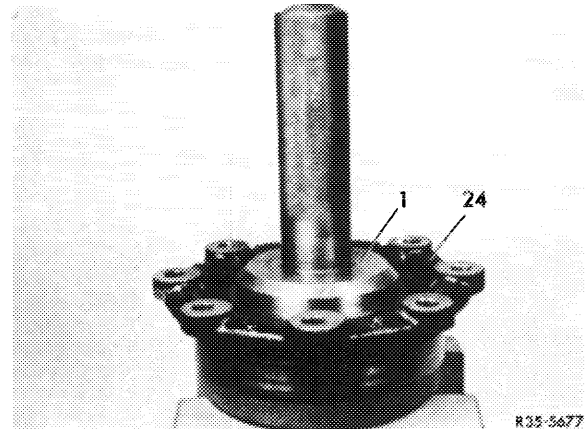

10 Force out bearing outer race by means of removing tool (1).

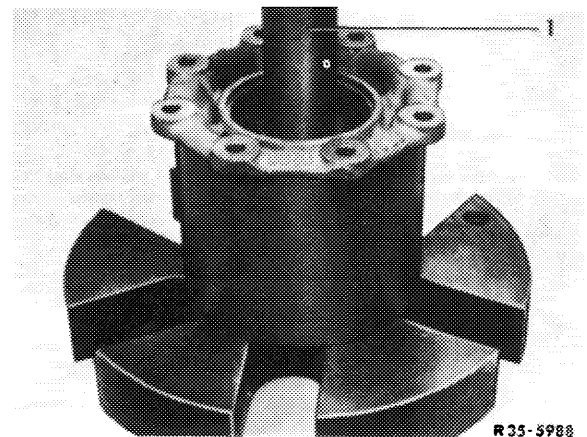

11 Take differential out of rear axle housing (large center piece).

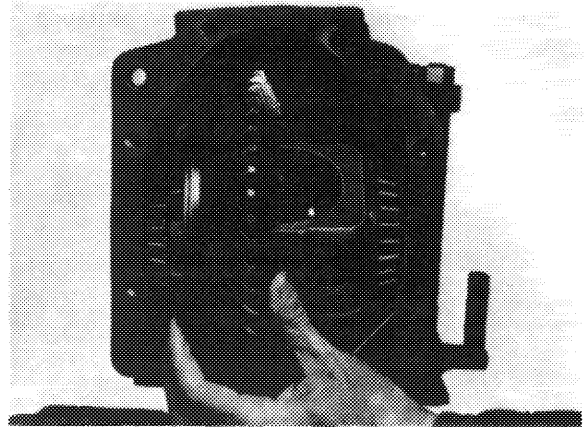

12 Move differential into position shown and take out of rear axle housing (small center piece).

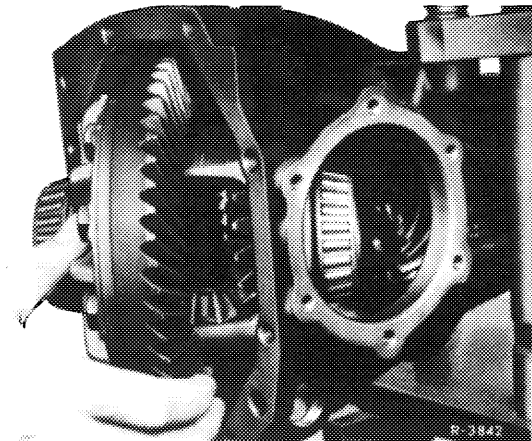

Note: If the wheel assembly is used again, mark position of ring gear in relation to differential housing, so that the ring gear is reinstalled in the same position as before.

13 Unscrew ring gear from differential housing and carefully push from housing.

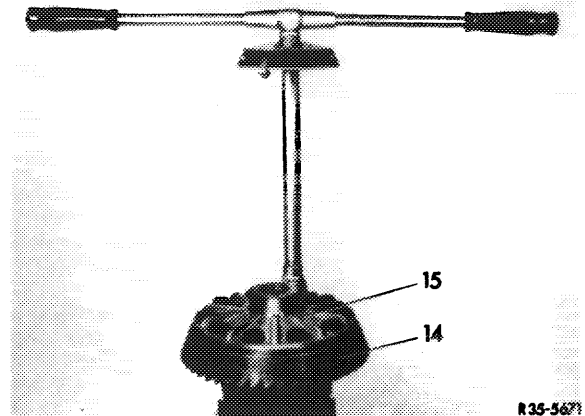

Removing and checking drive pinion

1st version

- 3 Rear axle housing
- 6 Drive pinion
- 7 Tapered roller bearing
- 8 Compensating washer
- 9 Spacing sleeve
- 10 Tapered roller bearing

- 11 Radial sealing ring
- 12 Universal flange
- 13 Self-locking slot nut (1st version)

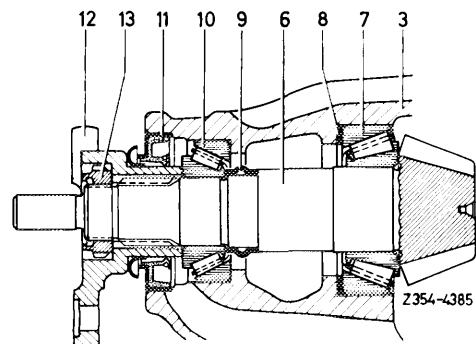

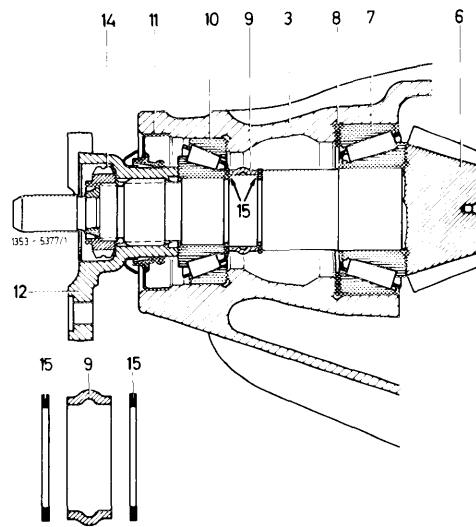

2nd version

- | | |
|---------------------------|---|
| 3 Rear axle housing | 11 Radial sealing ring |
| 6 Drive pinion | 12 Universal flange |
| 7 Tapered roller bearing | 14 Crush slot nut (2nd version)
or double hex. collar nut
(3rd version) |
| 8 Compensating washer | 15 Washer |
| 9 Spacing sleeve | |
| 10 Tapered roller bearing | |

14 Plug holding wrench (1) on universal flange and loosen self-locking or crush slot nut with slot nut wrench (2) or double hex. collar nut with double hex. socket.

15 Mark universal flange in relation to drive pinion.

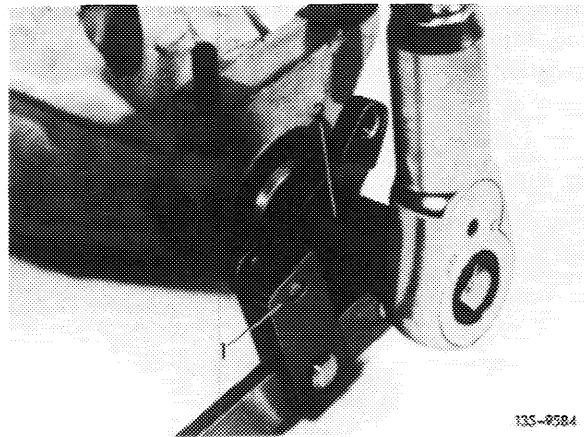

135-8584

16 Pull universal flange from drive pinion with puller, if required.

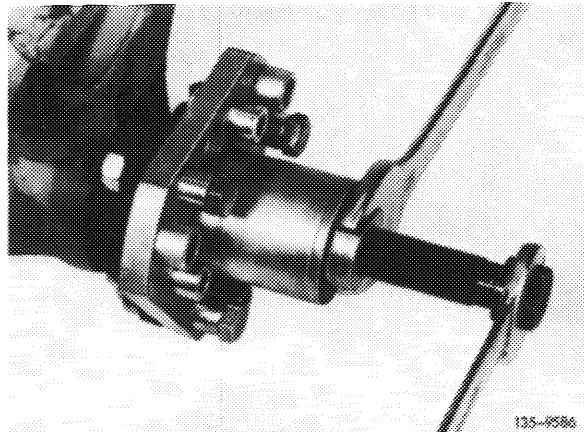

135-8586

17 Force drive pinion out of rear axle housing by means of a conventional puller.

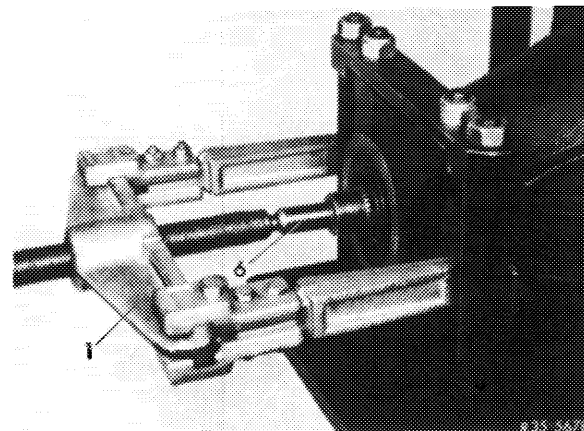

135-8587

18 Force radial sealing ring (25) out of rear axle housing by means of a screwdriver and remove tapered roller bearing inner race.

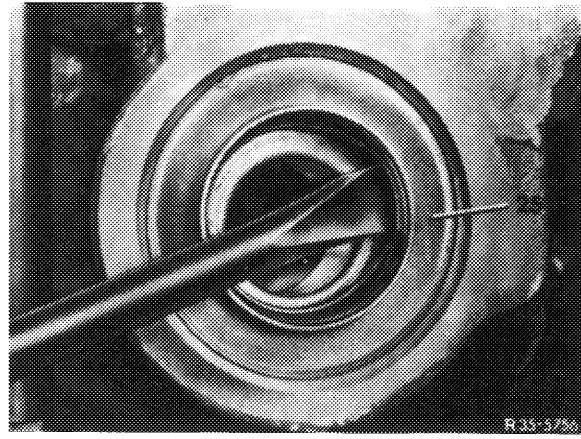

19 Screw installer and remover (1) to rear axle housing and pull inner tapered roller bearing outer race with compensating washer out of housing by means of pulling member (2).

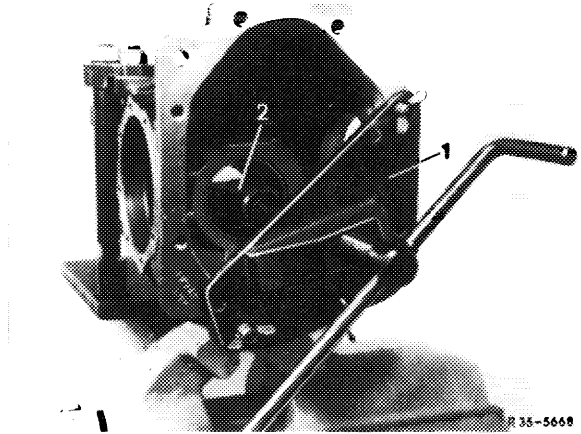

20 Force outside tapered roller bearing outer race out of rear axle housing by means of thrust member (1).

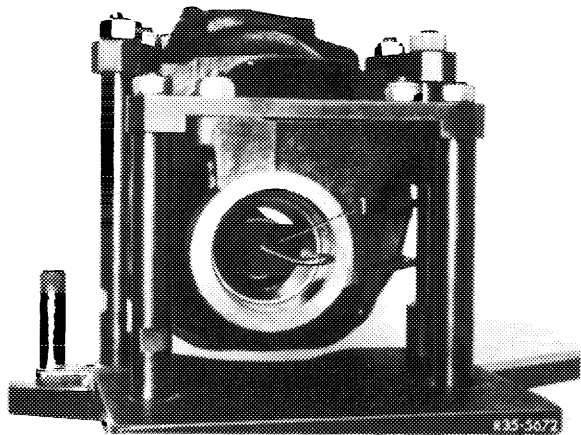

21 Remove spacing sleeve (44) together with thrust washers (48) from drive pinion.

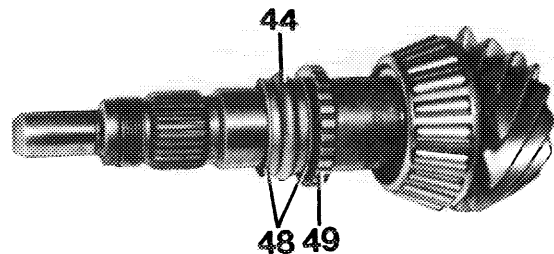

- 44 Spacing sleeve
- 48 Thrust washers
- 49 Gear wheel (on vehicles with ABS only)

135-19634