

## Vehicles with ABS

22 Pull gear wheel (rotor) from drive pinion by means of a conventional puller.

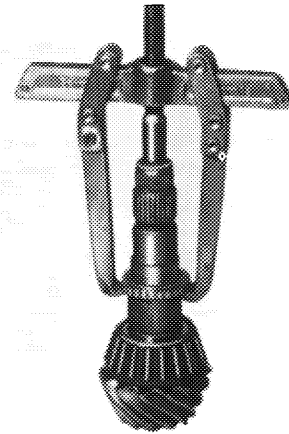

135-10655

23 Assemble puller (basic unit 024) with extension (024c) and clamp (024a).

24 Slip puller with clamp (024a) over tapered roller bearing and tighten clamp by means of clamping sleeve (024b) behind rollers of tapered roller bearing.

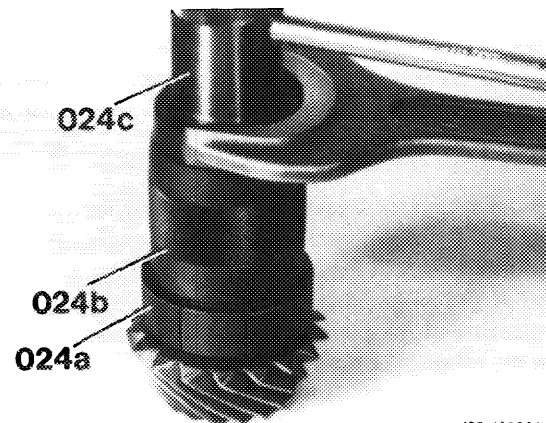

135-12264/1

25 Pull tapered roller bearing inner race from drive pinion by means of puller.

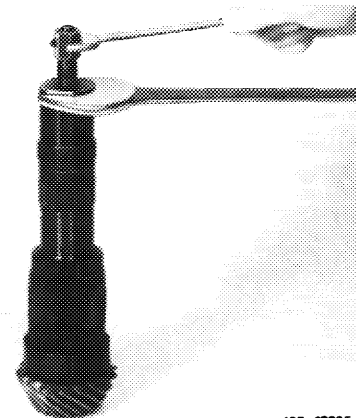

135-12265

## Checkup

26 Check all parts for re-use. Check bearing seats on drive pinion for radial and axial runout.

27 Check running surface for radial sealing ring on universal flange. If running surface is worn out or oil return feed thread on 1st version is damaged, replace universal flange.

28 Place universal flange on drive pinion while paying attention to mark. Check vertical runout of universal flange on running surface of radial sealing ring.

If in spite of repositioning universal flange several times the vertical runout on splining is higher than 0.06 mm, replace universal flange.

**Note:** Each drive pinion and ring gear belonging to one gear set is identified by means of a serial number written on both parts. In addition, the distance of the wheels in relation to each other for the respective gear set are also named on drive pinion.

To determine the thickness of the compensating washer required for adjusting the drive pinion, a data sheet should be used. **A sample data sheet is inserted at the end of this job number.** The measuring and computing procedure of the example shown is described in detail on the following pages.

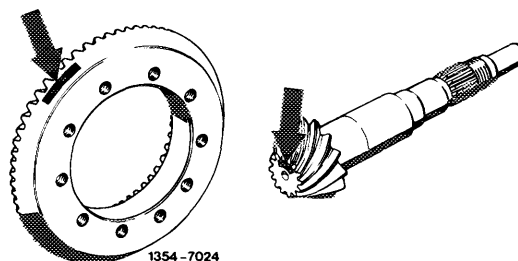

### Assembly and adjustment of gear assembly

29 Press rear tapered roller bearing (8) on drive pinion (6) by means of self-made pressing-on sleeve (1). For this purpose, use side of sleeve marked with "A" or "B" according to center piece.

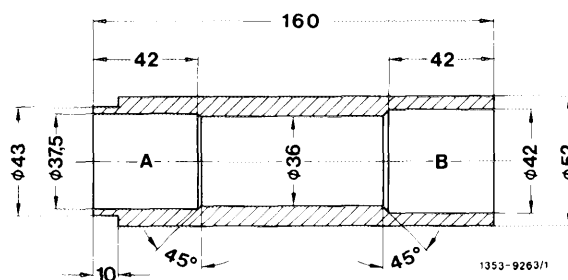
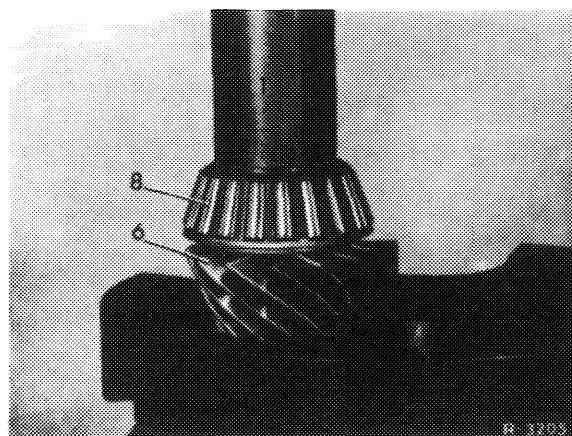

**Pressing-on sleeve (self-made)**

- A = for vehicles with small center piece
- B = for vehicles with large center piece

**Vehicles with ABS**

30 Press-on ring gear (rotor) with self-made installing sleeve.

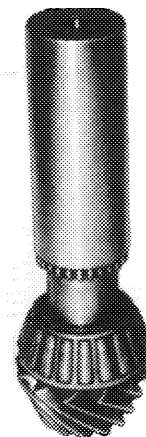

135-19640

31 Set dial gauge at approx. 3 mm preload on measuring body (051b) initially to 0.

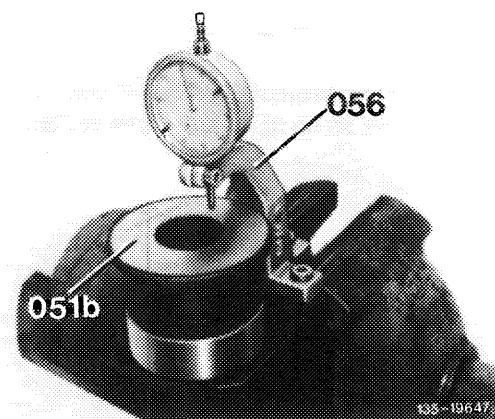

32 For small rear axle center pieces place outer bearing race on roller cage of drive pinion. Insert drive pinion into measuring device (1, 1st version) and measure drive pinion height with bearing. Record dimension which shows the difference between measuring body height "B1" and drive pinion height "B" on data sheet item 1.

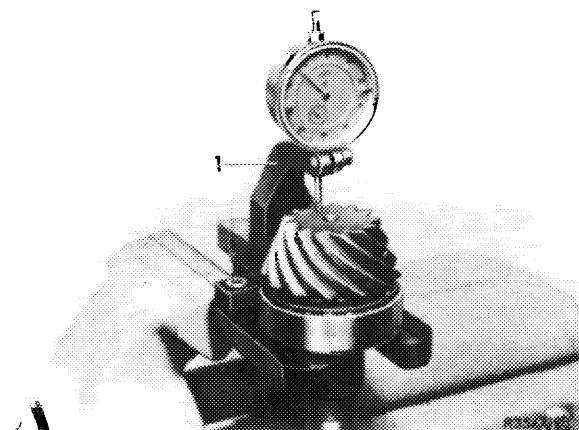

33 For large rear axle center pieces place outer bearing race on roller cage of drive pinion and attach magnetic plate (1). Place drive pinion into measuring device (2, 1st version) and measure drive pinion height with bearing and magnetic plate. Record dimension, which shows a difference between measuring body height "B1" and drive pinion height "B" on data sheet under item 1.

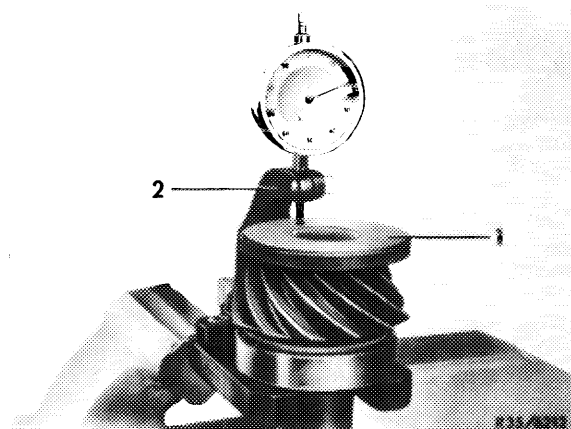

**Attention!**

For large rear axle center pieces drive pinions with a height of 37.5 mm and 39 mm were installed. Consequently, 1.5 mm must be entered under item 1 in data sheet for drive pinions with 39 mm height and then added.

With this change, the type of lock has been simultaneously changed from polystop (A) – to crush nut – slot nut (B, arrow).

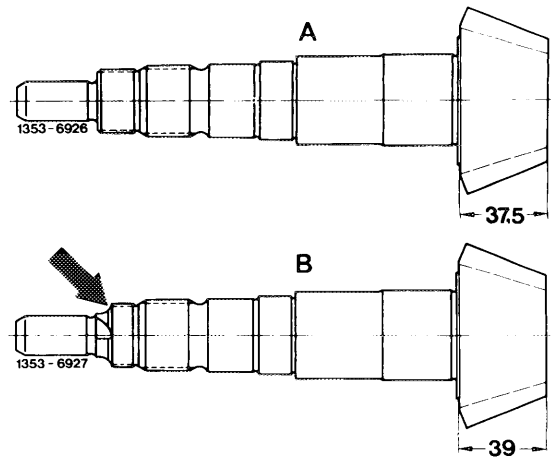

34 Enter basic deviation "a" of drive pinion (refer to arrow) (plus or minus) under item 2 in data sheet.

35 Add (+) or deduct (-) values of item 1 and 2 depending on prefix of value on drive pinion.



36 Insert device (1) with measuring body (2) in rear axle housing and screw-on measuring body (2).

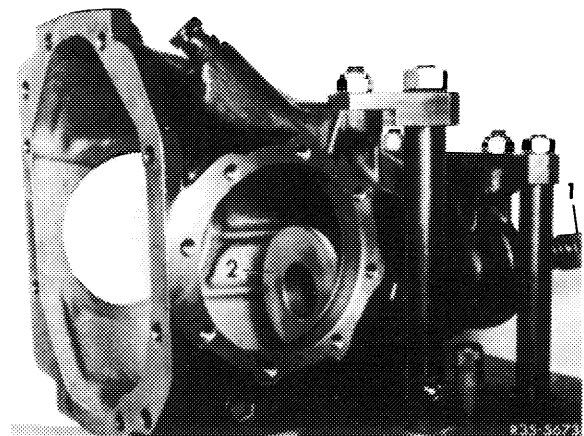

37 Insert dial gauge with dial gauge holder (2) into adjusting gauge (3) and set dial gauge under 3 mm preload to 0.

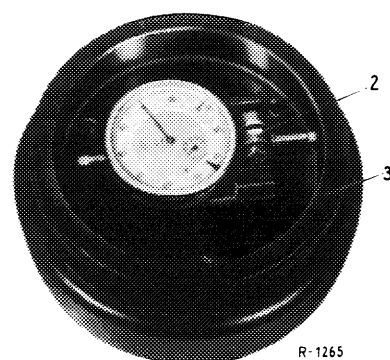

38 Insert mounting tool (2) together with dial gauge holder and dial gauge (3) into righthand bore of rear axle housing and screw down.

39 Read difference between preset gauge dimension and measuring body face and enter under item 3 in data sheet in plus or minus direction.

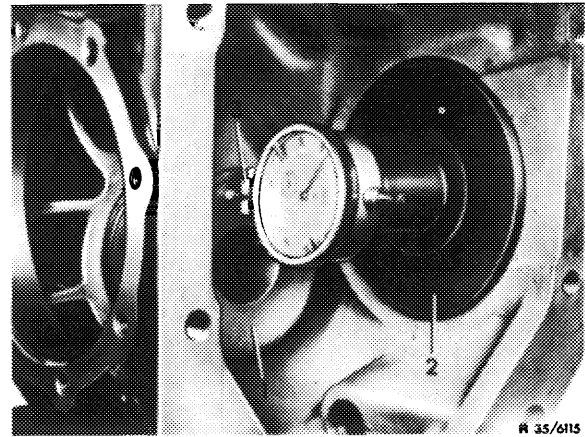

**Note:** The statement of direction plus (+) or minus (-) refers to rotation of dial gauge needle. A deviation from zero position in counterclockwise direction would be minus direction, in clockwise direction plus direction.

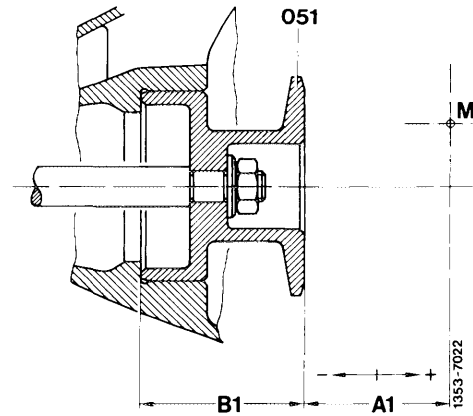

40 Add (+) or subtract (-) subtotal of values from item 1 and item 2, as well as from item 3. This computed value provides the thickness of the compensating washer.

Example:

Item 1		=	1.60
Item 2		=	+ 0.15
		=	--
<hr/>			
Subtotal		=	1.75
Item 3	minus direction	=	+ 0.06
	plus direction	=	--
<hr/>			
Thickness of compensating washer "S"		=	<u>1.81</u>

41 Remove mounting tool and measuring body out of rear axle housing.

42 Insert compensating washer with computed washer thickness "S" into rear axle housing (refer to example).

**Note:** Use hardened compensating washers only, they are available at varying thickness. If required, grind one compensating washer as required.

43 Insert outer races of front and rear tapered roller bearing into rear axle housing by means of installer.

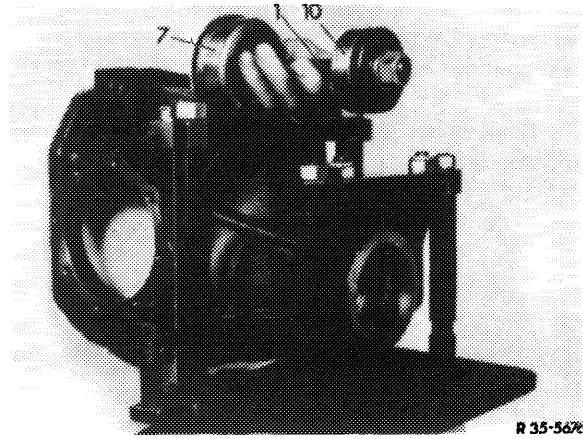

44 Add on both sides of spacing sleeve (9) one washer (15) each and place on drive pinion.

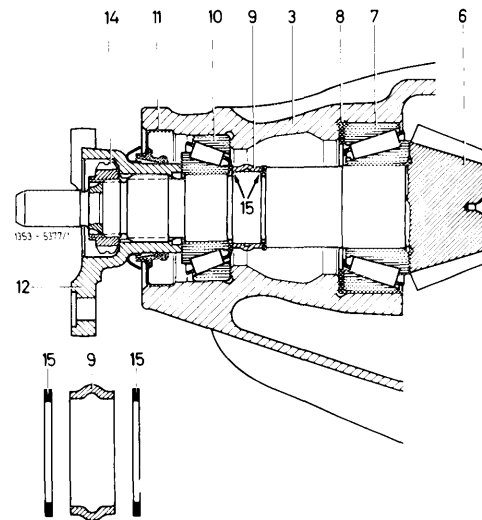

**Attention!**

On small rear axle center piece add washers only at drive pinion where dimension "a" amounts to 13.5 mm.

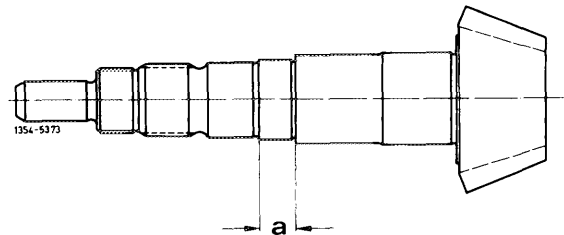

45 Insert drive pinion into rear axle housing and support with remover and installer (2).

46 Coat radial sealing ring with sheet-metal jacket at OD with sealing compound and radial sealing ring with rubber-coated jacket with hypoid gear oil or rubber sliding compound "naphtalene H" and put on thrust piece. Insert inner race of front tapered roller bearing and press-in together with radial sealing ring (11).

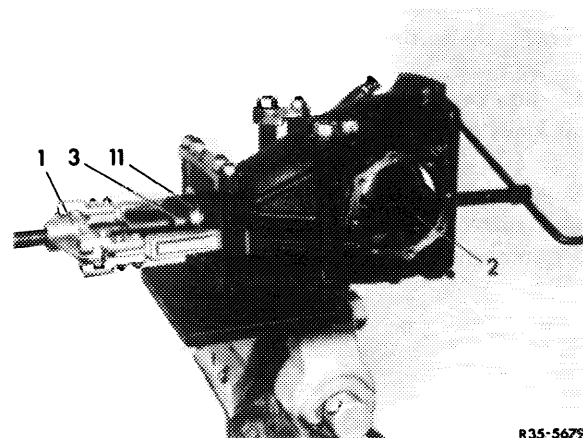

47 Coat running surface for radial sealing ring at universal flange with molybdenum disulfide paste and slip universal flange on drive pinion. Pay attention to mark which may have been applied during removal on universal flange and on drive pinion.

48 Take away remover and installer from rear axle housing.

**Attention!**

On drive pinion of 1st version without groove on threads (A) mount self-locking slot nut (polystop slot nut, a) only.

On drive pinion of 2nd version with nut (B) optionally use a crush slot nut (b) with a groove on circumference or a double hex. collar nut (c). Other installation combinations are not permitted.

- A = Drive pinion without groove
- a = Polystop slot nut
- B = Drive pinion with groove
- b = Crush slot nut

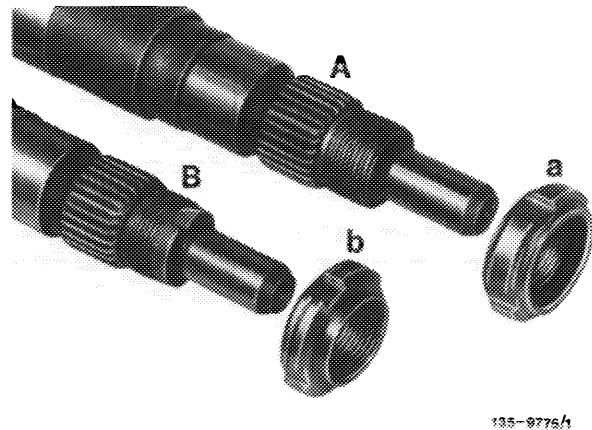

135-9776/1

- B = Drive pinion with groove
- b = Crush slot nut
- c = Double hex. collar nut

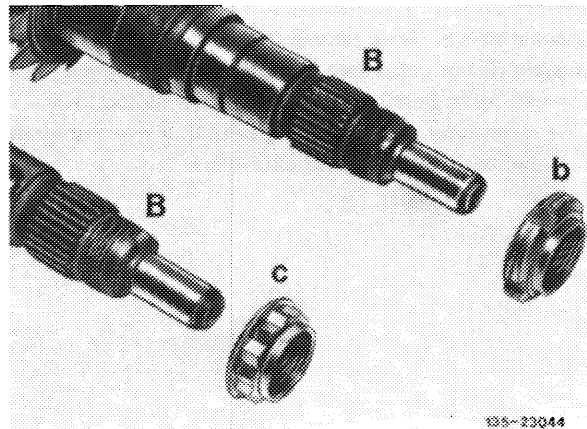

135-23044

49 Screw-on new self-locking or crush slot nut or double hex. collar nut. Plug holding wrench on universal flange, and carefully tighten slot nut or double hex. collar nut until friction torque of 120–140 Ncm on new bearings and of 50–100 Ncm on used bearings is attained.

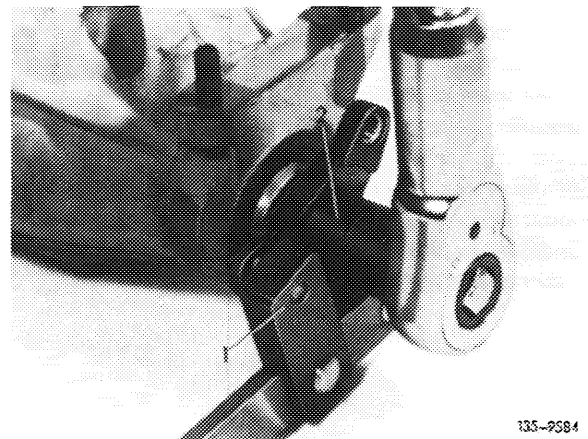

135-9584

**Attention!**

**When tightening slot nut or double hex. collar nut, turn drive pinion several times and apply light blows against rear axle housing to make sure that the tapered rollers are settling well in races.**

50 To check, plug torque measuring instrument (018) with connecting member on slot nut wrench (016) and rotate drive pinion.

**Note:** The tapered roller bearings of the drive pinion must be installed at a given preload. This preload is attained by compressing the spacing sleeve located between the bearing inner race of the front tapered roller bearing and the drive pinion when tightening the slot nut or collar nut.

If the friction torque, that is, the preload of the tapered roller bearings, is too low when rotating the drive pinion, tighten slot nut or collar nut a little more. If the specified friction torque is exceeded, remove drive pinion once again and install a **new** spacing sleeve. **Never reduce friction torque by releasing slot nut or collar nut**, since the preload of the tapered roller bearing would then become too low. The result would be play of drive pinion while driving coupled with noises in rear axle drive.

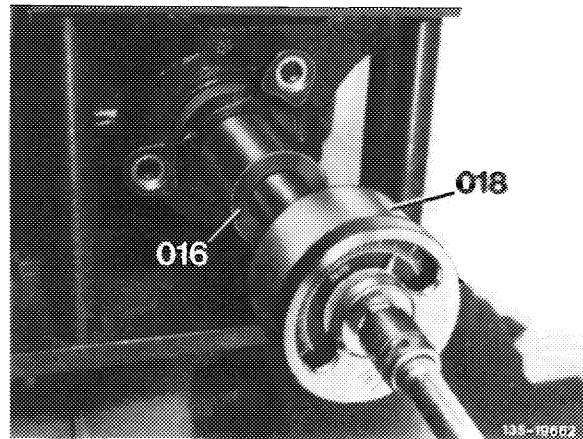

51 Install measuring tool together with dial gauge holder and dial gauge again into righthand bore of rear axle housing to check adjustment. For measuring the adjusting dimension "A" position magnetic measuring plate on face of drive pinion.

For the gears of the example shown the dial gauge should indicate a deviation of 0.15 mm from basic dimension in plus direction, the same dimension which is written on face of drive pinion.

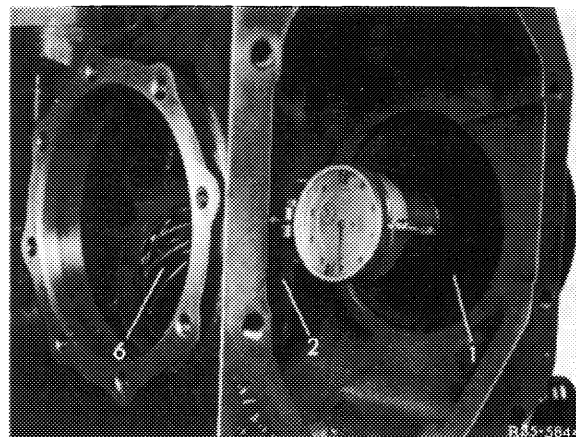

The permissible basic deviation of adjusting dimension "A" should not exceed plus 0.01 and minus 0.02.

When the deviation is larger, grind removed compensating washer to required size or install a new compensating washer of pertinent thickness. Also make sure that a **new spacing sleeve** is used for the tapered roller bearings.

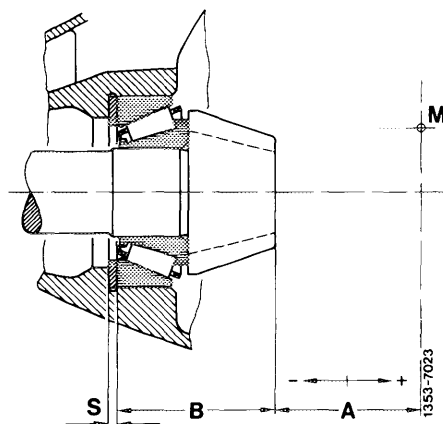

52 Remove measuring tool and dial gauge with holder from rear axle housing.

53 Peen crush slot nut or double hex. collar nut with a peening tool into one of the two grooves of drive pinion in such a manner that no gap is provided between groove and locking tab.

**Attention!**

Do not apply any heavy blows in axial direction.

Crush slot nut  
 Dimensions for peening tool  
 a = approx. 8 mm  
 b = approx. 4 mm

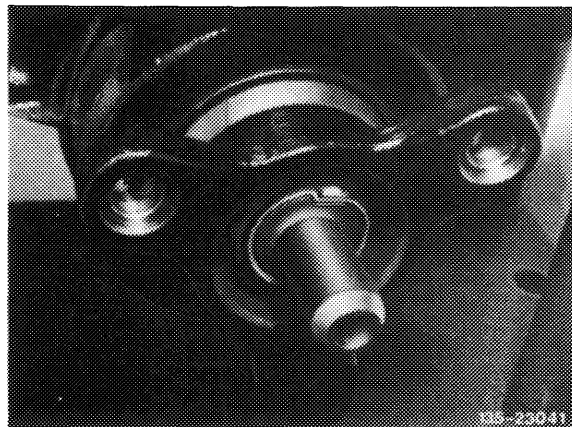
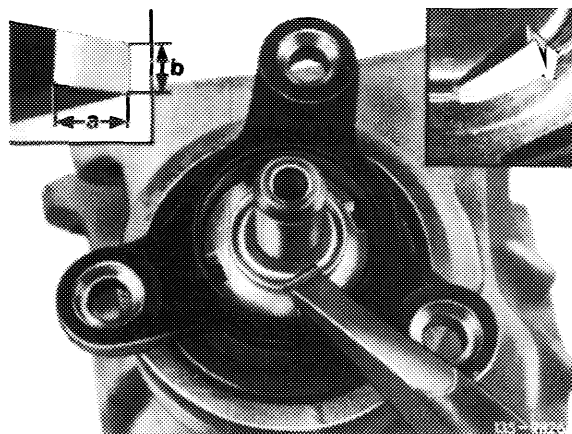

Double hex. collar nut

**Press radial sealing ring and tapered roller bearing outer race into lateral bearing cap**

54 Press new tapered roller bearing outer race with disc from installing tool (2) and installing sleeve (1) into bearing cap (24).

In the case of rear axle center piece press in with disc of 74.8 mm dia.

In the case of large rear axle center piece press in with disc of 88 mm dia.

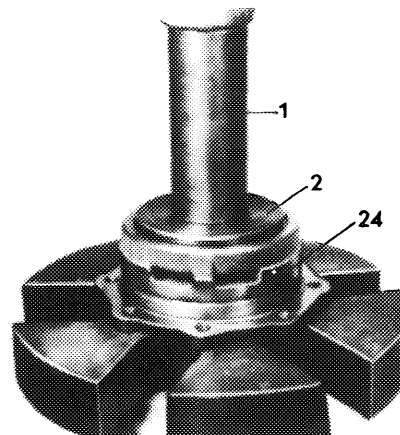

55 Coat new radial sealing ring with sheet-metal jacket on OD with sealing compound, radial sealing ring with rubber-coated jacket with hypoid gear oil or rubber sliding compound "naphtalene H" and press into bearing cap (24) up to stop by means of installer (1).

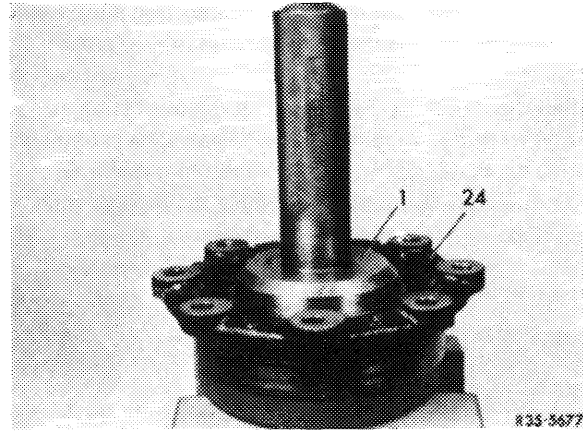

**Attention!**

Three bearing cap versions are available for vehicles with large rear axle center piece.

1st and 2nd version with 65 mm dia. radial sealing ring

3rd version with 81 mm dia. radial sealing ring.

On 1st version, push radial sealing ring in until the installation mandrel rests against lug for dirt labyrinth of bearing cap.

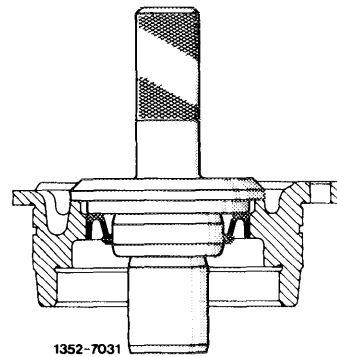

**Radial sealing ring correctly inserted**

On 2nd version, insert radial sealing ring until the insertion mandrel is flush with bottom edge of chamfer (lug for dirt labyrinth is shortened) of bearing cap.

To avoid overpressure against radial sealing ring, make a spacing ring according to drawing and use.

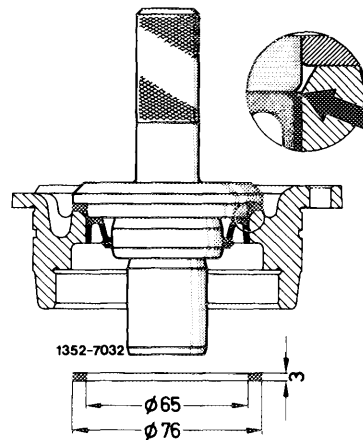

**Radial sealing ring correctly inserted**

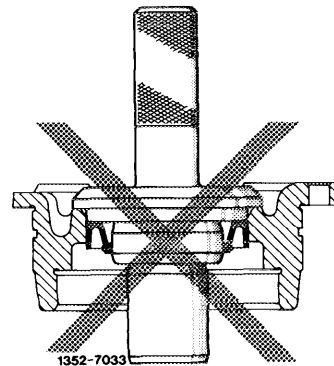

**On 2nd version radial sealing ring wrongly inserted**

On 3rd version, press new radial sealing ring of 81 mm OD up to stop into bearing cap by means of installer (014).

**Note:** Coat radial sealing rings with rubber jacket with hypoid gear oil or rubber sliding compound "naphthalene H" on OD.

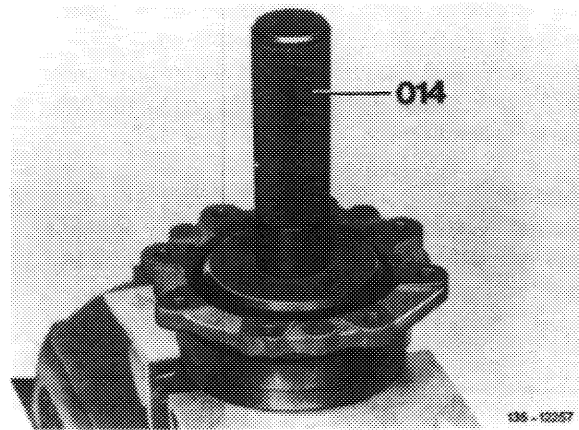

### Adjusting backlash

**Note:** The backlash of the gear assembly and the required preload of the tapered roller bearings in relation to bearings of differential are adjusted by means of compensating washers between the bearing caps and the rear axle housing. Compensating washers are available at varying thickness. For assembly, re-installation of the previously removed bearing caps and compensating washers on pertinent side will be best.

56 Disassemble and assemble differential (35–560).

57 Carefully clean bore of ring gear and seat on differential housing. Heat ring gear to approx. 70–80 °C and place on differential housing. Check markings on ring gear and differential housing, previously applied.

If the ring gear cannot be placed on differential housing, assist by means of light hammer blows (rubber hammer).

#### Attention!

When installing a new differential housing or when using new ring gear screws, pay attention to length of ring gear screws. On small rear axle center piece with contact flange dimension "B" 8 mm thick use ring gear screws 18 mm long only, and for contact flange 10 mm thick use ring gear screws 20 mm long only. On large rear axle center piece with contact flange dimension "B" 8 mm thick, use ring gear screws 20 mm long only, and for contact flange 10 mm thick use ring gear screws 22 mm long.

Always renew ring gear screws after one-time use on principle.

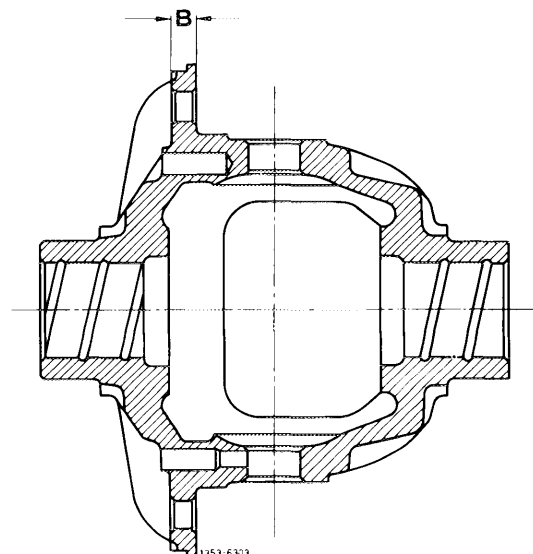

58 Crosswise tighten hex. head screws for fastening ring gear uniformly to 80 Nm, self-locking hex. head screws to 100 Nm on small center piece and 120 Nm, self-locking hex. head screws to 140 Nm on large center piece.

**Attention!**

Renew ring gear screws on principle after one-time use. Standard fastening screws can be replaced by self-locking hex. head screws, but not vice versa.



59 Insert differential with righthand side first into bore of lateral bearing cap until the differential can be introduced into the rear axle housing at the left.

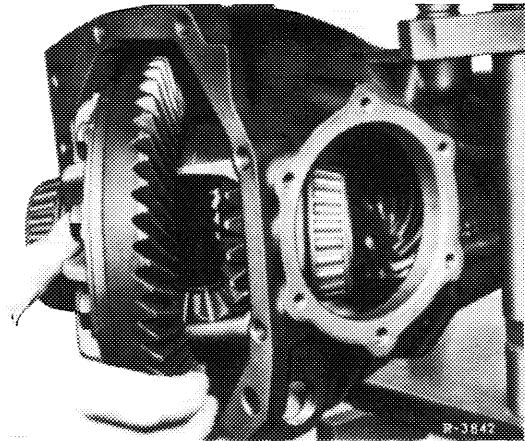

Small center piece

60 Place differential into rear axle housing.

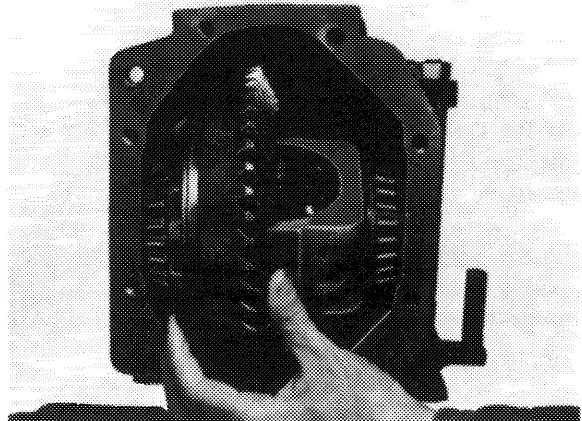

Large center piece

61 Place the previously removed compensating washers (23) on bearing cap (24) and insert new sealing rings (22) into grooves of bearing cap.

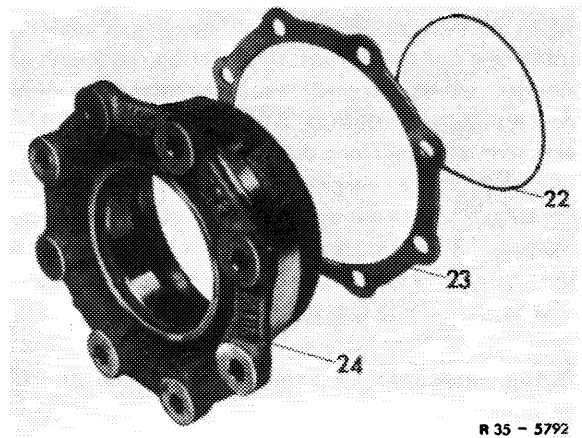

62 On 1st version only, mount both bearing caps with the designation "unten" (bottom) at the bottom. For the other versions, the position of the bearing cap is not important.

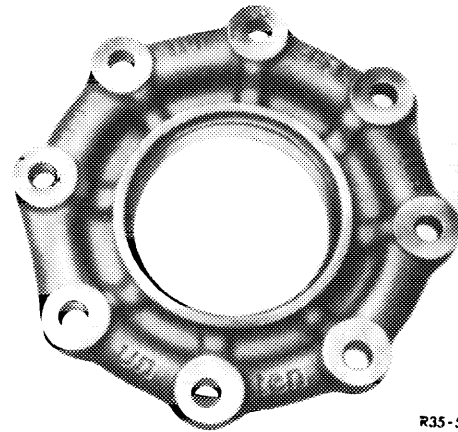

R35-5759

63 Slip both bearing caps with the initially mounted compensating washers into rear axle housing.

**Note:** If the bearing caps bind in bore of rear axle housing, settle caps by applying light hammer blows (rubber hammer) (arrows).

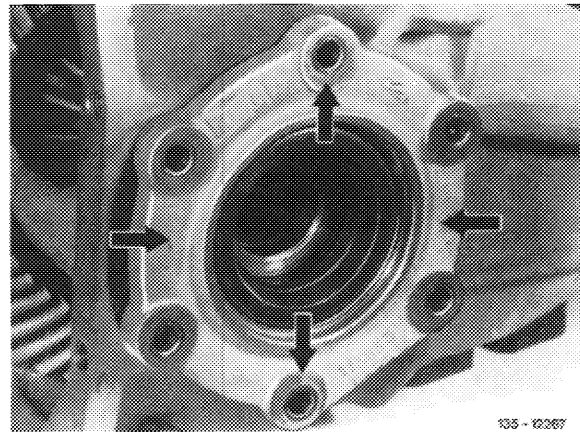

135-12267

64 Screw supporting blocks for spread measuring instrument at the right and left to sealing surface of rear axle housing. Place spread measuring instrument with dial gauge on supporting blocks and set dial gauge under preload to "0".

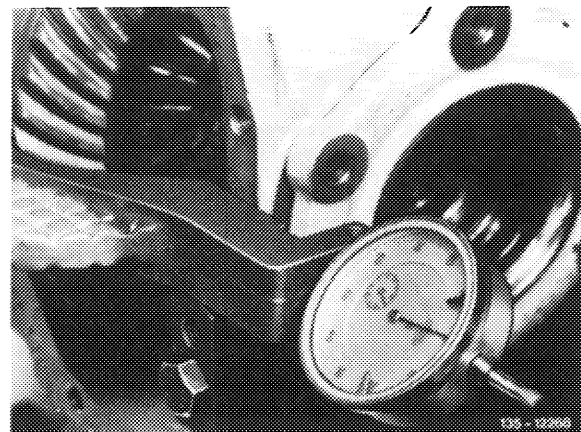

135-12268

65 Screw-in all hex. screws on bearing caps and tighten crosswise to 20 Nm.

66 Place spread measuring instrument again on supporting blocks and measure spread (widening) of rear axle housing. The required spread dimension of rear axle housing and thereby the correct preload of tapered roller bearings on differential is attained as soon as the spread dimension in range of small center piece is between 0.10–0.15 mm, and on large center piece between 0.15–0.20 mm.

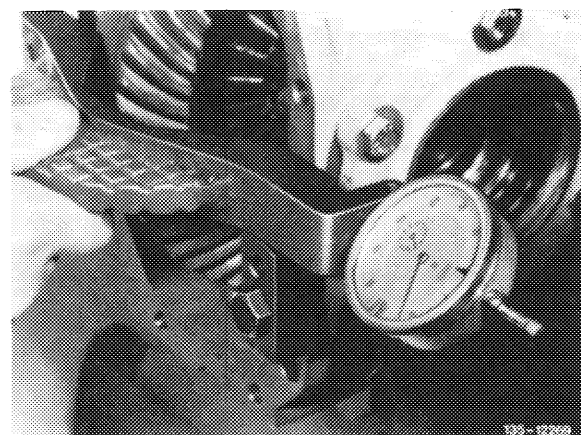

135-12269

67 Insert backlash gauge into righthand bore of differential housing and clamp down.

68 Measure backlash at four points with reference to circumference of ring gear by moving dial gauge holder accordingly. The smallest play counts. **The backlash should amount to 0.08 to 0.14 mm.** Hold drive pinion in place at universal flange when measuring.

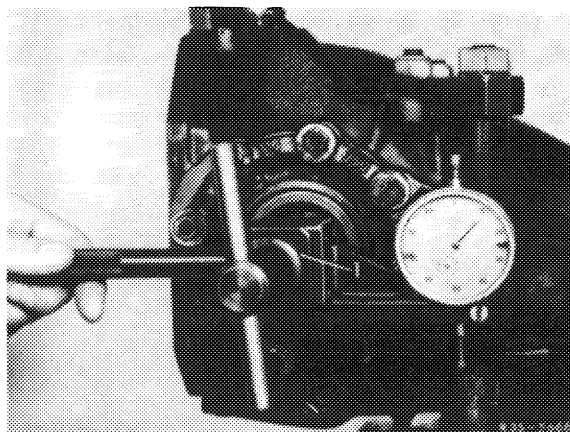

**Note:** The adjustment of the tapered roller bearings and the gear assembly is in order when the spread (widening) of rear axle housing and the backlash are in range of nominal values. If these values are not attained, repeat adjustments using pertinently thicker or thinner compensating washers (23).

**Example 1:** If the backlash is in order, but the spread of the rear axle housing is insufficient, use compensating washers for both bearing caps which are each thinner by a uniform amount.

**Example 2:** If the spread is in order but the backlash is too high, remove compensating washers of pertinent size from the left and add at the right. If backlash is too low, proceed vice versa.

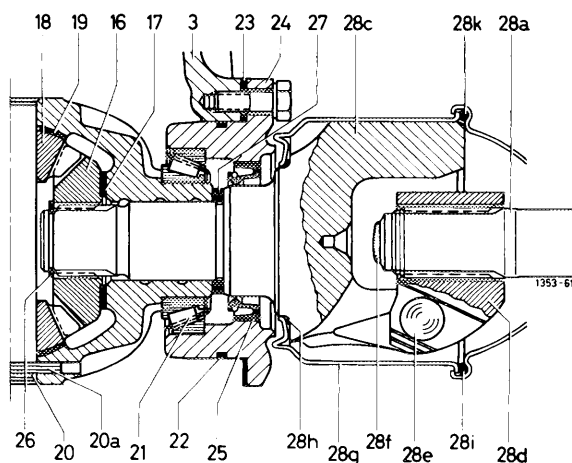

69 Install left-hand and right-hand rear axle shaft with new locking rings (35-620).

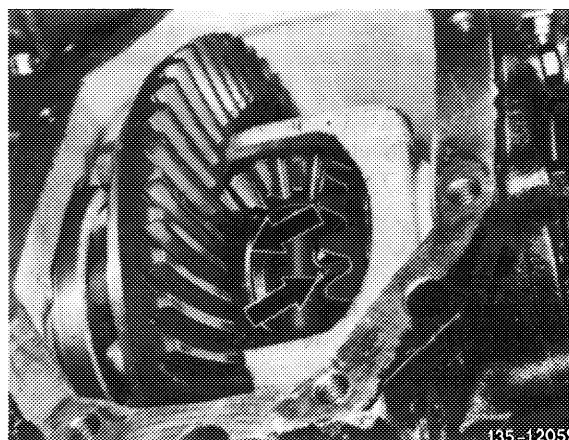

70 Clean sealing surface on end cover and rear axle housing and coat with sealing compound. Mount rear axle end cover (4). Tightening torque of hex bolts 45 Nm.

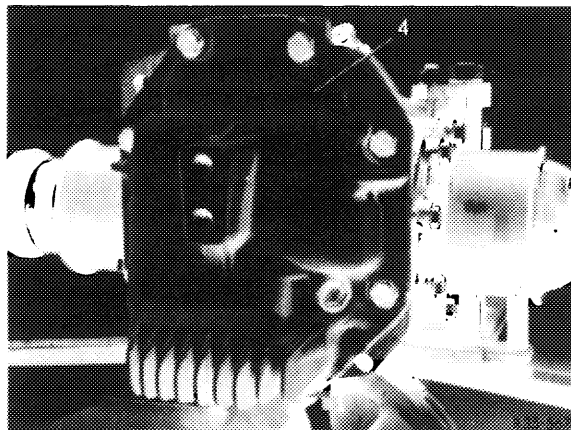

71 Fill-in hypoid gear oil up to lower edge of oil filler hole.

72 Renew breather on rear axle end cover.