

33-430 Replacement of rubber sleeves for supporting and guide joint of steering knuckle bearing

Lubricants

	Amount of grease	Type of grease
Supporting joint	approx. 10 cm ³ (9 gr)	Longterm grease, see "Specifications for service products", page 266.2
Guide joint	approx. 8 cm ³ (7 gr)	

Notes

Replace damaged boots only during assembly jobs.
Never replace damaged or leaking boots on joints already in use. In such a case, be sure to replace the joint or the pertinent control arm.

Removal

1 Lift circlip at one end with a screw driver and remove in direction of arrow.

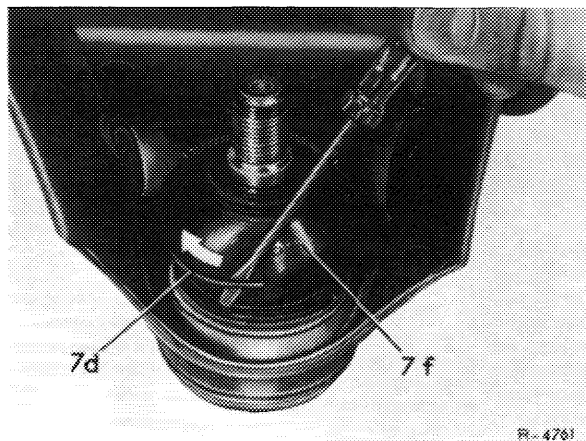

7d Circlip
7f Boot

Pl. 4763

Supporting joint

- 7a Housing
- 7b Ball shell
- 7c Ball pin
- 7d Circlip
- 7e Washer
- 7f Boot
- 7g Supporting ring
- 7h Clamping ring
- 7i Lower ball socket

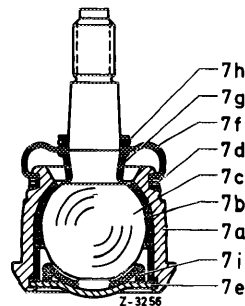

Z-3256

2 Remove used grease from ball joint.

Guide joint

- 6a Housing
- 6b Ball socket
- 6c Ball pin
- 6d Circlip
- 6e Washer
- 6f Boot
- 6g Supporting ring
- 6h Clamping ring

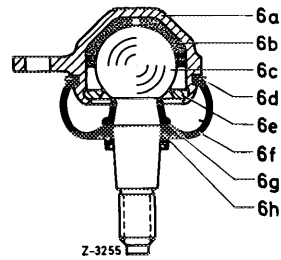

Installation

3 Fill space between housing and ball pin with fresh grease.

4 Place ball pin in vertical position and mount new boot with clamping ring inserted.

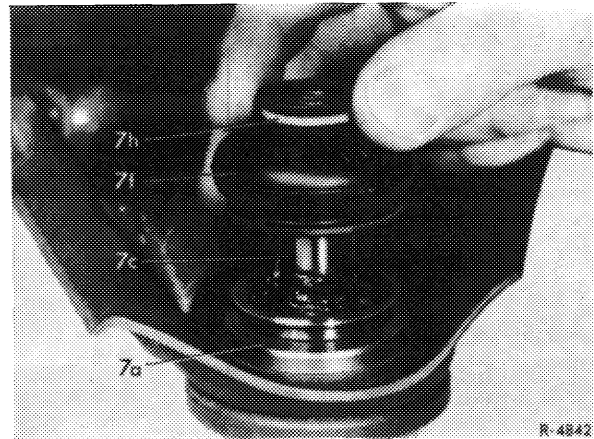

Supporting joint

- 7a Housing
- 7c Ball pin
- 7f Boot
- 7h Clamping ring

5 Slide circlip (7d) on suitable assembly boot (69a) in such a manner that the cylindrical portion of the boot (refer to arrow) is attained.

6 Place assembly boot on supporting or guide joint in such a manner that the groove for the seat of the circlip on sleeve remains just free. Then slide circlip on sleeve of joint.

7 Check seat of installed sleeve.

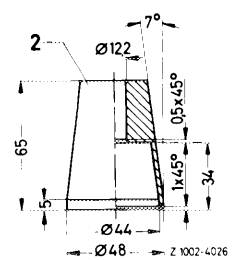
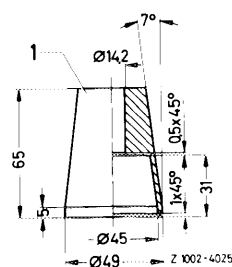
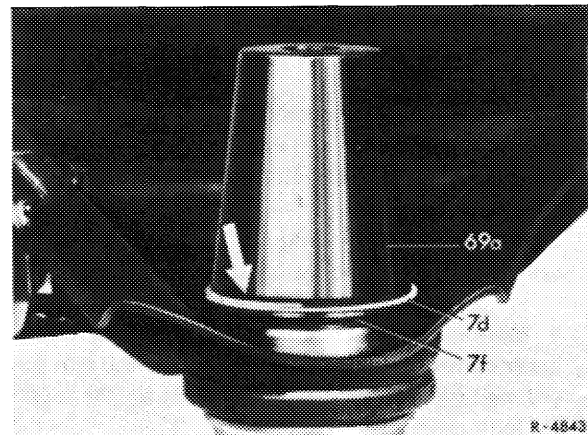

Self-made assembly sleeves

- 1 Assembly sleeve for supporting joint
- 2 Assembly sleeve for guide joint