

Tightening torques	Nm
Hex. bolts of steering knuckle arm	80
Hex. nut of guide joint	60
Hex. nut of supporting joint	80
Self-locking hex. screw for fastening rpm sensor to steering knuckle	8

**Special tools**

Spring tensioner for front spring	107 589 03 31 00
Remover for supporting and guide joint	115 589 02 33 00
Socket wrench insert 24 mm, 1/2" square drive for spring tensioner	116 589 01 09 00

**Notes**

When the work is done above the pit, do not mount supports for jacking-up the vehicle as usual on frame floor, but outside under lower control arms. The front shock absorbers should remain installed.

If, for example when working on the lifting platform, the lower control arm cannot be supported, secure by inserting spring tensioner (74).

- 74a Tensioning bolt
- 74d Lower thrust piece
- 74e Guide bushing
- 74f Collar nut
- 74g Upper thrust piece

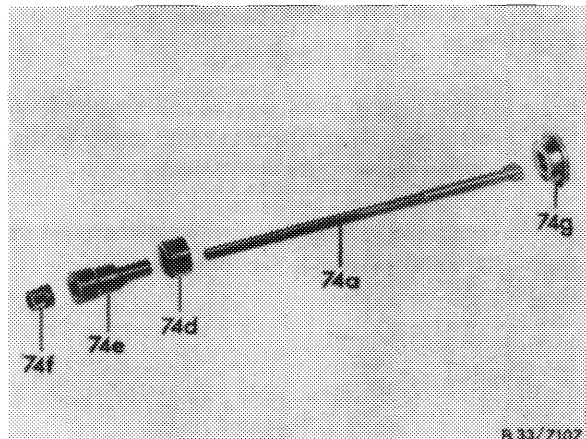

- 3 Lower control arm
- 4 Upper control arm
- 10 Front spring
- 74 Spring tensioner

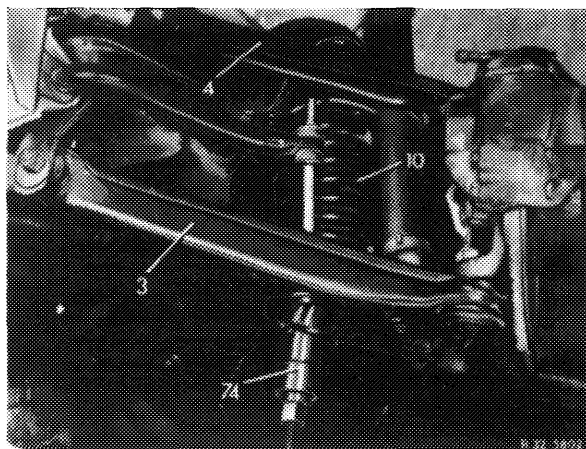

For this purpose, place the additional plate of spring tensioner against spring dome of front axle carrier. In such a case, the shock absorber can also be removed.

**Never loosen the hex. nuts of the guide joint and the supporting joint with the shock absorber removed without inserting the spring tensioner.**

- 1 Front axle carrier
- 74a Tensioning bolt
- 74g Clamp plate

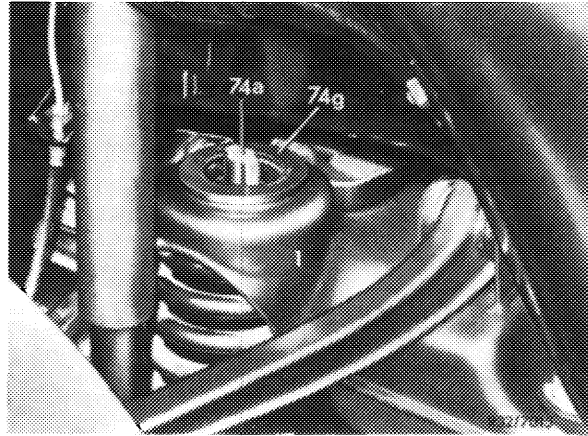

## Removal

1 Unscrew steering knuckle arm from steering knuckle.

- 5 Steering knuckle
- 6 Guide joint
- 7 Supporting joint
- 11 Front shock absorber
- 18 Fixed caliper
- 24 Steering knuckle arm
- 27 Torsion bar connecting linkage
- 32 Cover plate
- 33 Holder for brake hose

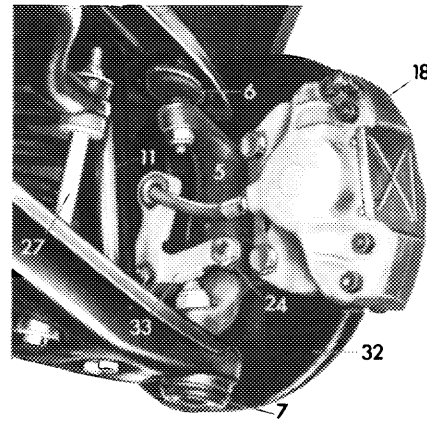

R 32- 5609

2 Separate brake line and brake hose from each other. Close connections with rubber plugs.

3 Remove fixed caliper (42–100).

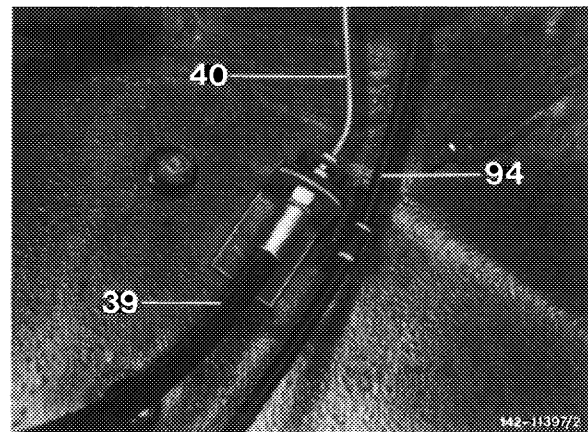

442-11397/2

4 Unscrew hex. nut on supporting joint (7) and on guide joint (6).

5 Remove supporting joint and guide joint with remover (41) from steering knuckle. Remove steering knuckle.

- 3 Lower control arm
- 4 Upper control arm
- 5 Steering knuckle
- 6 Guide joint
- 7 Supporting joint
- 41 Remover

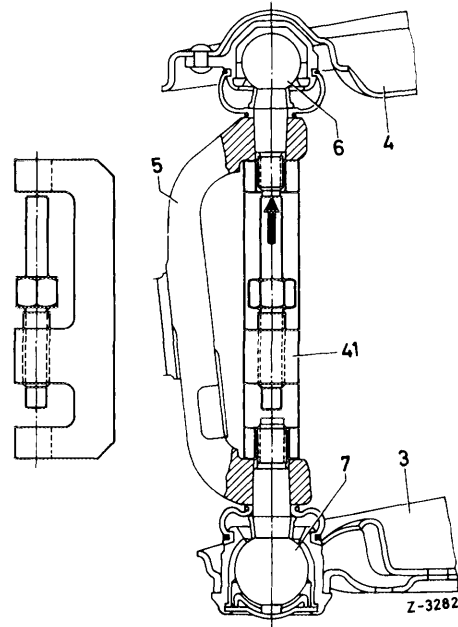

### Installation

6 Attach upper and lower control arm to steering knuckle. Make sure that the seats of the ball pins for the supporting and guide joint are kept free of grease.

#### Steering knuckle bearings

- 3 Lower control arm
- 4 Upper control arm
- 5 Steering knuckle
- 6 Guide joint
- 7 Supporting joint
- 8 Front wheel hub
- 9 Brake disc
- 24 Steering knuckle arm
- 32 Cover plate
- 35 Disc wheel

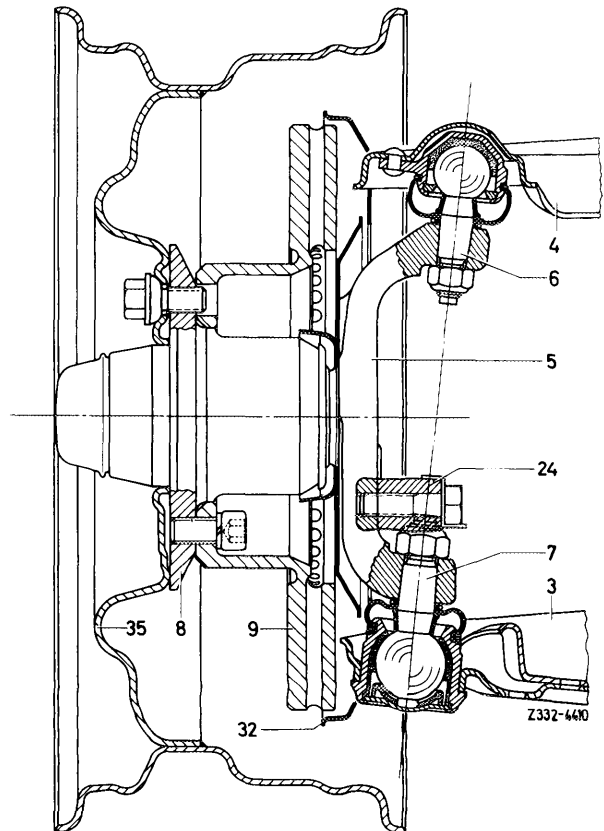

7 If the ball pin on the guide or supporting joint keeps turning when the hex. nut is being tightened, insert a spacing piece and pull the ball pin head into the steering knuckle by tightening the hex. nut.

Then loosen hex. nut, remove spacing piece and tighten hex. nut to the prescribed torque.

- 5 Steering knuckle
- 6 Guide joint
- 73 Spacing piece

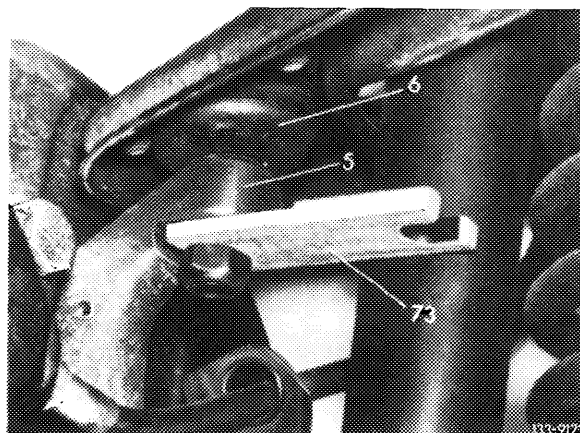

The spacing piece can be self-made.

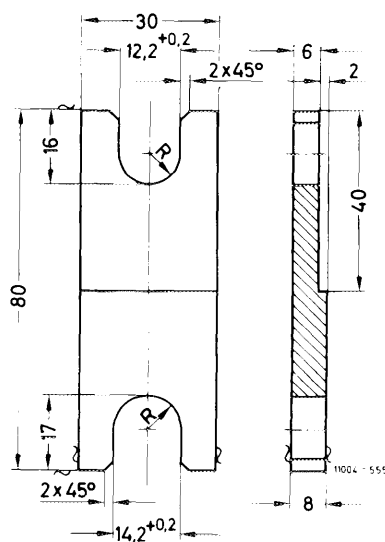

8 Install fixed caliper (18) (42–100).

9 Install steering knuckle arm using new holder for brake hose.

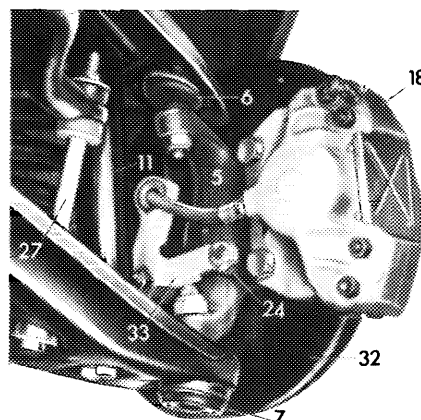

R 32-5609

10 Connect brake line and brake hose to each other.

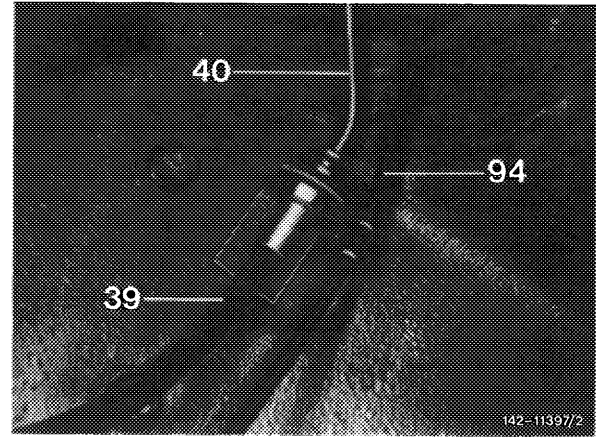

11 Bleed braking system (42-010).

12 Check wheel adjustment on front axle and correct, if required (40-320).

13 Check headlight adjustment.