

## 33–110 Removal, installation and inspection of rubber mounts for front axle suspension (front axle installed)

---

Tightening torques	Nm
Hex. bolts for rubber mounts of suspension on frame floor	45
Hex. nuts of lower shock absorber suspension	20
Hex. bolts of front engine mounting	35
Hex. nuts of track rod joints	35
Self-locking hex. head screw for fastening rpm sensor to steering knuckle	8

### Special tools

Carrying stirrup for engine	107 589 02 61 00
Puller for track rod ball joints	124 589 01 33 00

### Note

---

The front shock absorbers are simultaneously serving as a deflection stop for the front wheels. Therefore loosen shock absorber suspension only when the vehicle is on its wheels or when the lower control arm is supported.

There is a safety stop between the upper control arm and the front axle carrier.

Renew self-locking screws and nuts on principle!

### Removal

---

- 1 Remove both front shock absorbers (11) (32–100).
- 2 Jack-up vehicle at the front and rear while making sure that all the four supporting stands are set to the same height. Remove front wheels.

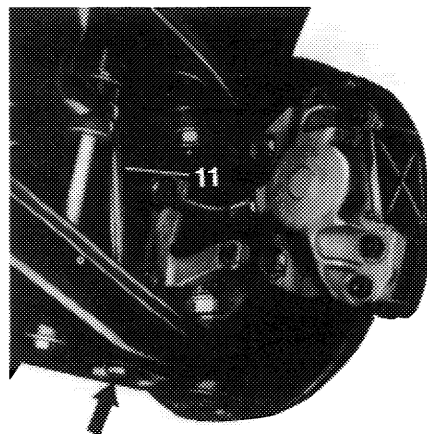

133-5609/2

3 Attach engine carrying stirrup.

4 Remove right and left hexagonal bolts from front engine suspension.

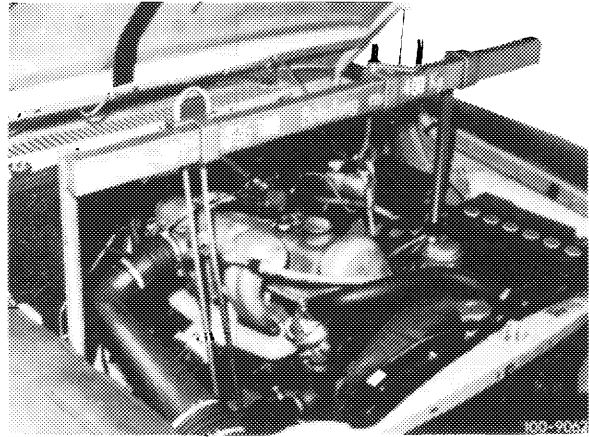

5 Separate brake line and brake hose from each other. Block the connection with rubber plugs.

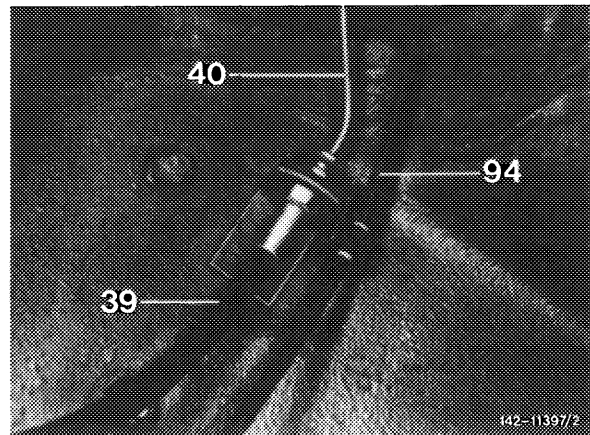

6 Remove tie rods from both steering knuckle arms.

- 20 Tie rod
- 24 Steering knuckle arm
- 36 Remover

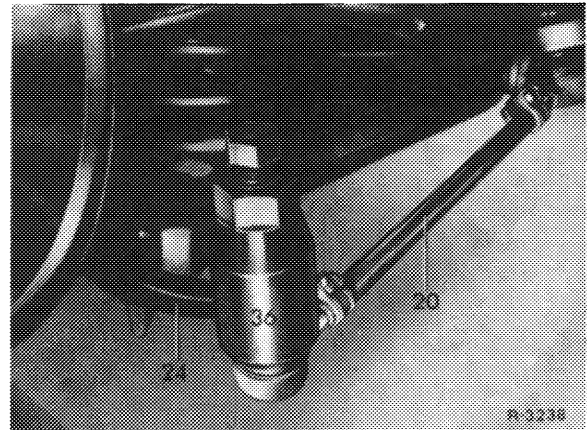

7 On vehicles with engines 110, 115, 130, 180 and 615, 616, 617, detach engine shock absorber from front axle carrier.

- 1 Front axle carrier
- 26 Engine shock absorber
- 39 Holder for engine shock absorber

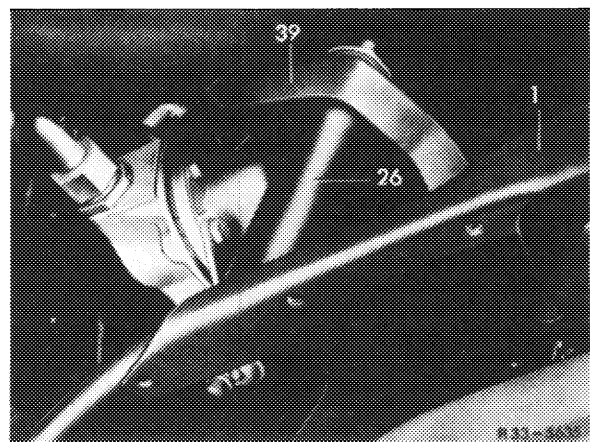

8 On vehicles with engines 115, 615 and 616, detach engine movement limiter from front axle carrier.

- 1 Front axle carrier
- 12 Torsion bar
- 41 Engine movement limiter

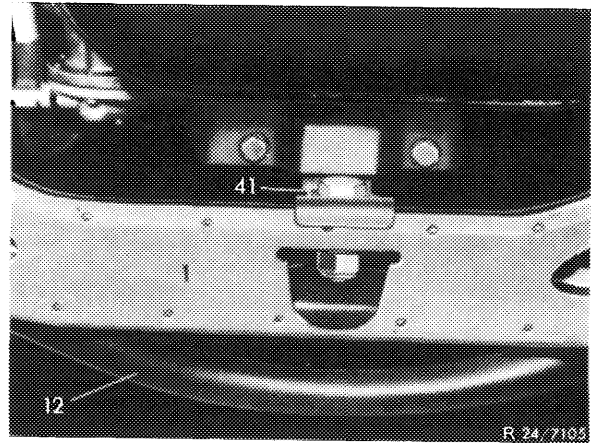

9 Support the front axle carrier with a pit lift and mounting (43) with supplementary part (43a).

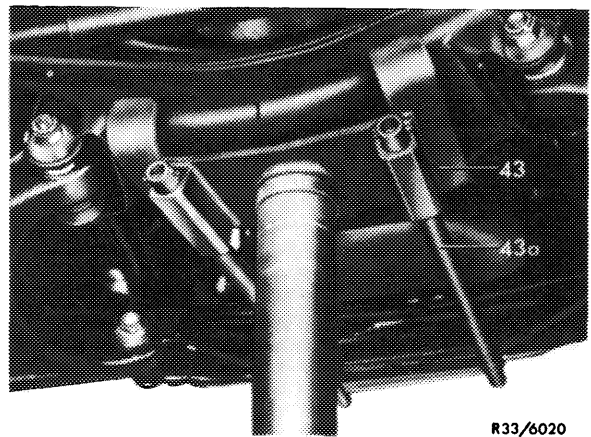

10 Loosen hex. head screws (2) of the four rubber mounts for front axle suspension on frame floor.

- 1 Front axle carrier
- 2 Rubber mount
- 3 Lower control arm
- 20 Tie rod
- 21 Drag link
- 23 Steering intermediate arm
- 24 Steering knuckle arm
- 25 Steering shock absorber
- 26 Eccentric bolts

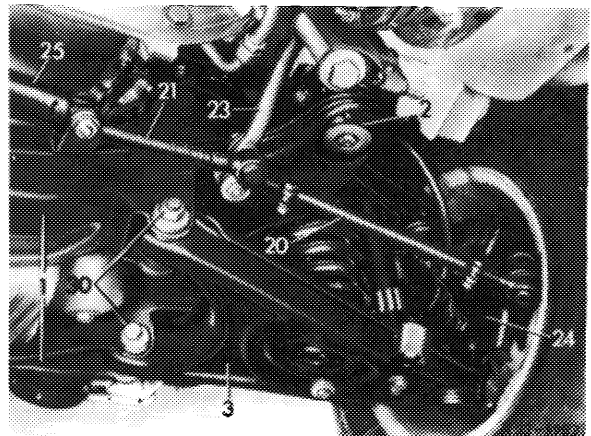

11 Lower pit lift approx. 50 mm and knock the rubber mounts (2) out of their seats in the front axle carrier from below (see arrow).

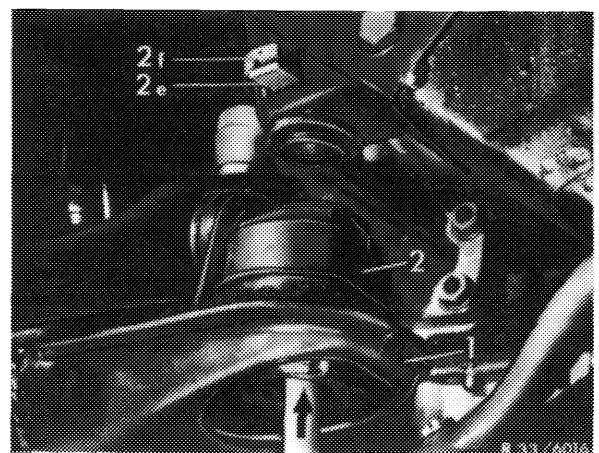

**Note:** On vehicles with longer wheelbase 3400 mm, models 114.008, 114.017, 115.103, 115.108, 115.112 and 115.119 there are washers (2g) between the front axle carrier and the rubber mount.

- 1 Front axle carrier
- 2 Rubber mount for front axle suspension
- 2g Washers  
for front rubber mounts 2 mm thick  
for rear rubber mounts 4 mm thick

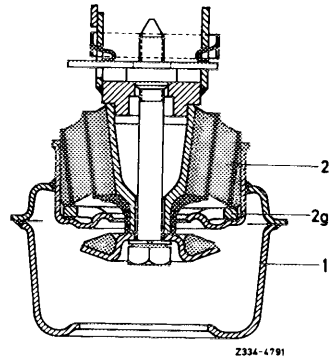

### Checking the rubber mounts

- 12 Check that inner sleeve fits tightly in rubber mantle.
- 13 Check for cracks and damage on buffer stops for spring compression and rebound.

### Installation

- 14 Push the buffer stop for spring compression (2a) onto the rubber mounts (2).

- |                                       |                                 |
|---------------------------------------|---------------------------------|
| 2 Rubber mount                        | 2d Hex. bolt with spring washer |
| 2a Buffer stop for spring compression | 2e Fastening nut                |
| 2b Stop plate                         | 2f Holder for fastening nut     |
| 2c Buffer stop for spring rebound     |                                 |

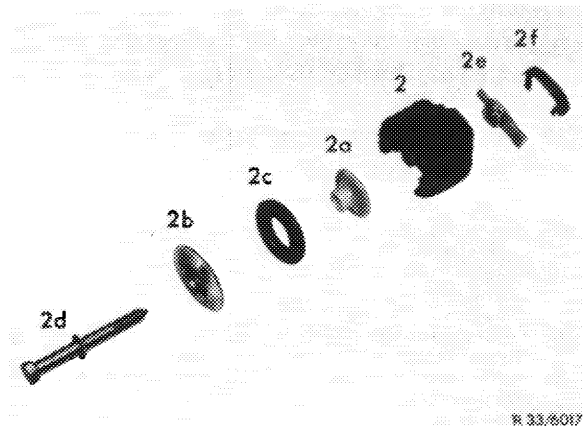

**Note:** For assembly of fastening nuts (2f) insert holder (2e) (if available).

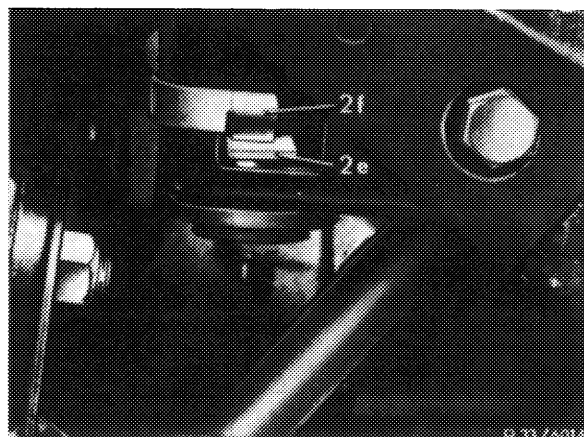

- 2e Fastening nut
- 2f Holder for fastening nut

15 Apply lubricant "Naphtalen" (Part No. 000 989 14 60) to the rubber mount circumference.

**On no account use oil or grease!**

16 Press the rubber mounts into their seats in the front axle carrier.

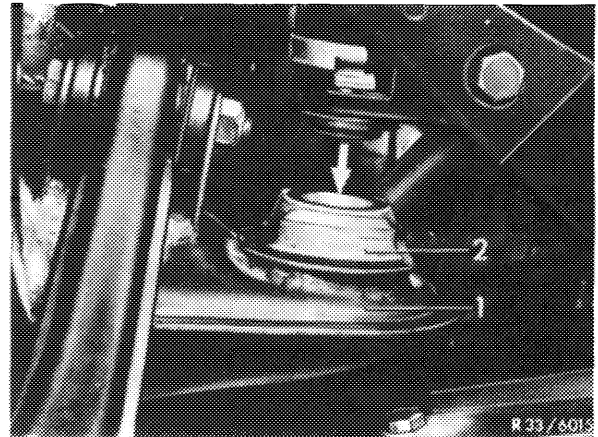

- 1 Front axle carrier
- 2 Rubber mount

**Attention!**

On vehicles with longer wheelbase 3400 mm, models 114.008, 114.017, 115.103, 115.108, 115.112 and 115.119, do not forget the washers (2g).

- 1 Front axle carrier
- 2 Rubber mount for front axle suspension
- 2g Washers for front rubber mounts 2 mm thick for rear rubber mounts 4 mm thick

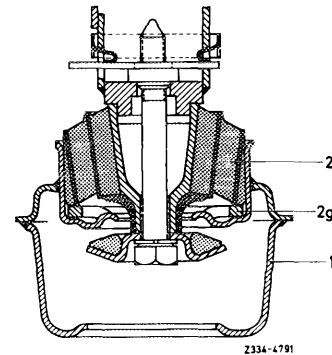

17 Lift the front axle carrier with the pit lift, taking care that the rubber mount inner sleeve is correctly positioned on the frame.

18 Mount the front axle carrier on the frame floor with the hex. bolts.

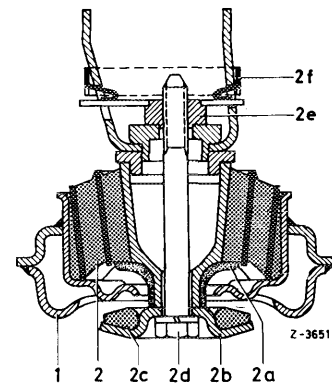

- |                                       |                                   |
|---------------------------------------|-----------------------------------|
| 1 Front axle carrier                  | 2c Buffer stop for spring rebound |
| 2 Rubber mount                        | 2d Hex. bolt with spring washer   |
| 2a Buffer stop for spring compression | 2e Fastening nut                  |
| 2b Stop plate                         | 2f Holder for fastening nut       |

19 Remove engine carrying stirrup. Install hex. bolts for engine suspension.

20 On vehicles with engines 115, 130, 180 and 615, 616, 617 mount engine shock absorber suspension on front axle carrier.

21 On vehicles with engines M 115 and 615, 616 mount the engine movement limiter on the front axle carrier.

22 Install the tie rod joints.

23 Connect brake hoses.

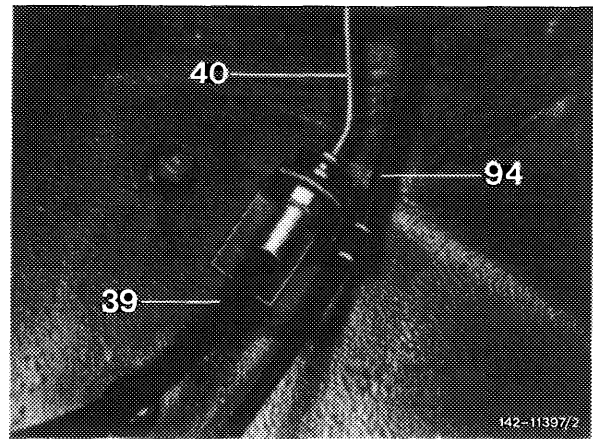

24 Screw lower shock absorber suspensions right and left to lower control arms (arrow).

25 Lower vehicle.

26 Bleed brake system (42-010).

27 Check headlight adjustment.

