

Model	M 116	M 117
Height "A" of cylinder crankcase when new	215.85–216.0	244.85–245.0
Minimum height following required material removal	215.65	244.65
Perm. roughness of parting surfaces	in longitudinal direction	0.08
	in crosswise direction	0.05
Perm. roughness of upper parting surface		0.02
Test pressure with air under water in atü		3
Distance from piston crown to parting surface cylinder crankcase, piston may project		0.030–0.75

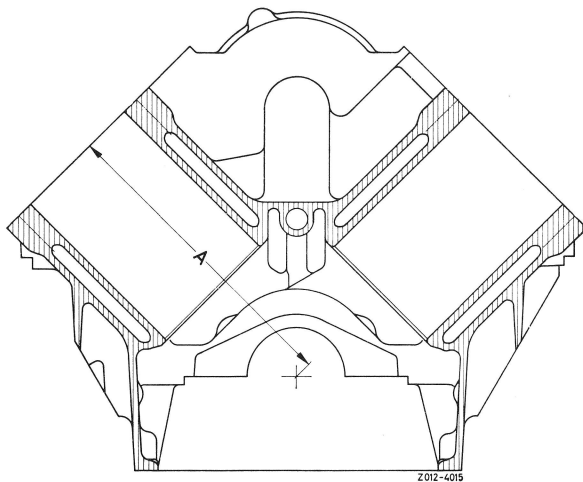

Fig. 1