

Coolant pump, coolant thermostat, inlet connection

Engines 116.960 and 116.961 standard version, 117.960 and 117.961

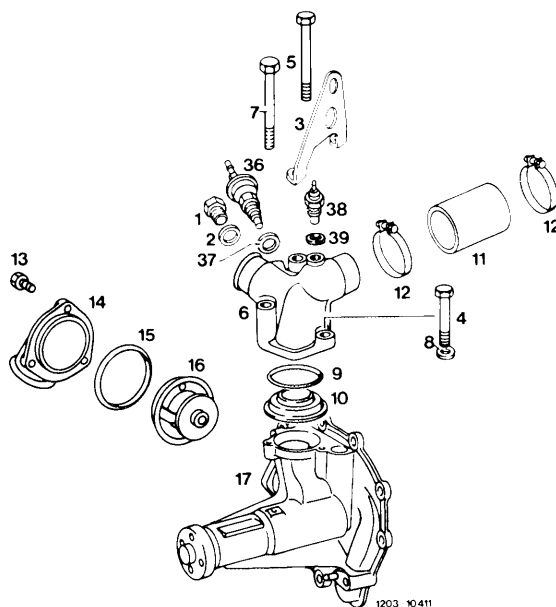

- 1 Closing plug M 14 x 1.5, vehicles without air conditioner and automatic climate control
- 2 Sealing ring A 14 x 18 – Cu
- 3 Suspension eye
- 4 Hex. head bolt M 8 x 30, 25 Nm
- 5 Hex. head bolt M 8 x 65, 25 Nm
- 6 Inlet connection
- 7 Hex. head bolt M 8 x 85, 25 Nm
- 8 Washer A 8, 4, 1 each
- 9 Sealing ring Check, renew if required
- 10 Spacer ring .
- 11 Coolant hose 42 x 51 x 40
- 12 Hose clamp L 45–35, 2 each
- 13 Combination screw M 6 x 20, 3 each, 10 Nm
- 14 Coolant thermostat cover
- 15 Sealing ring Check, renew if required
- 16 Coolant thermostat Start of control 75^{+1}_{-3} °C, end of control (fully opened) max. 92 °C. Ensure correct installation position
- 17 Coolant pump
- 36 Temperature switch On: 110^{+2}_{-3} °C, Off: 105 ± 3 °C. Switches second stage supplementary fan on vehicles with air conditioner or automatic climate control
- 37 Sealing ring A 14 x 18 – Cu
- 38 Temperature transmitter For coolant temperature indicator in instrument cluster Installed in right-hand cylinder head up to the end of November 1980
- 39 Sealing ring A 14 x 18 – Cu

Coolant pump, coolant thermostat, inlet connection

Engines 116.960 and 116.961 national versions **AUS** **J** **S** **USA** 1981

Engines 116.962, 116.963, 117.962 and 117.963

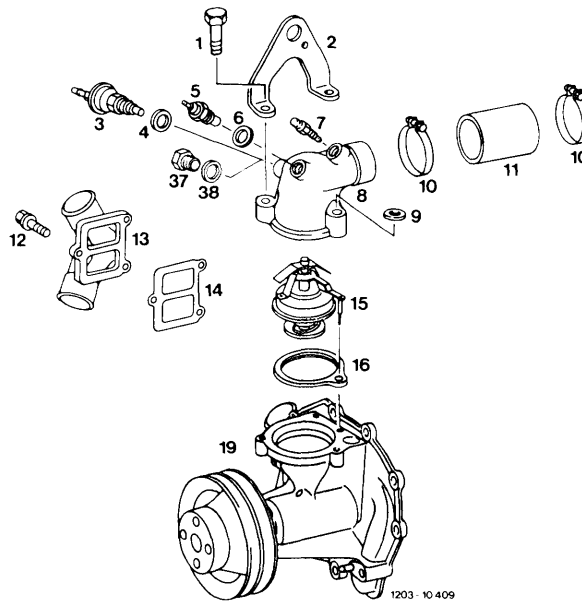

- | | | |
|----|-------------------------|--|
| 1 | Hex. head bolt | M 8 x 35, 3 each, 25 Nm |
| 2 | Suspension eye | |
| 3 | Temperature switch | For second stage supplementary fan on vehicles with air conditioner or automatic climate control
100 °C On: 110 ⁺² / ₋₃ °C, Off: 105 ± 3 °C |
| 4 | Sealing ring | A 14 x 18 – DIN 7603 – AL |
| 5 | Temperature transmitter | For coolant temperature indicator in instrument cluster |
| 6 | Sealing ring | A 14 x 18 – DIN 7603 – AL |
| 7 | Vent screw | Only engines 116.960 and 116.961 national versions
AUS J S USA 1981 to August 1981 |
| 8 | Inlet connection | |
| 9 | Washer | A 8, 4, 1 each |
| 10 | Hose clamp | L 45–35, 2 each |
| 11 | Coolant hose | 45 x 51 x 58 |
| 12 | Combination screw | M 6 x 22, 10 Nm |
| 13 | Cover | |
| 14 | Gasket | Renew |
| 15 | Coolant thermostat | Start of control 84 ± 2 °C, end of control (fully opened) max. 99 °C, no vent valve, observe installation instructions |
| 16 | Gasket | Check, renew if required |
| 19 | Coolant pump | |
| 37 | Closing plug | M 14 x 1.5 AL alloy, vehicles without air conditioner or automatic climate control |
| 38 | Sealing ring | A 14 x 18 – DIN 7603 – AL |

Coolant pump, coolant thermostat inlet connection

**Engines 116.964/965 standard version
117.964/965/967/968**

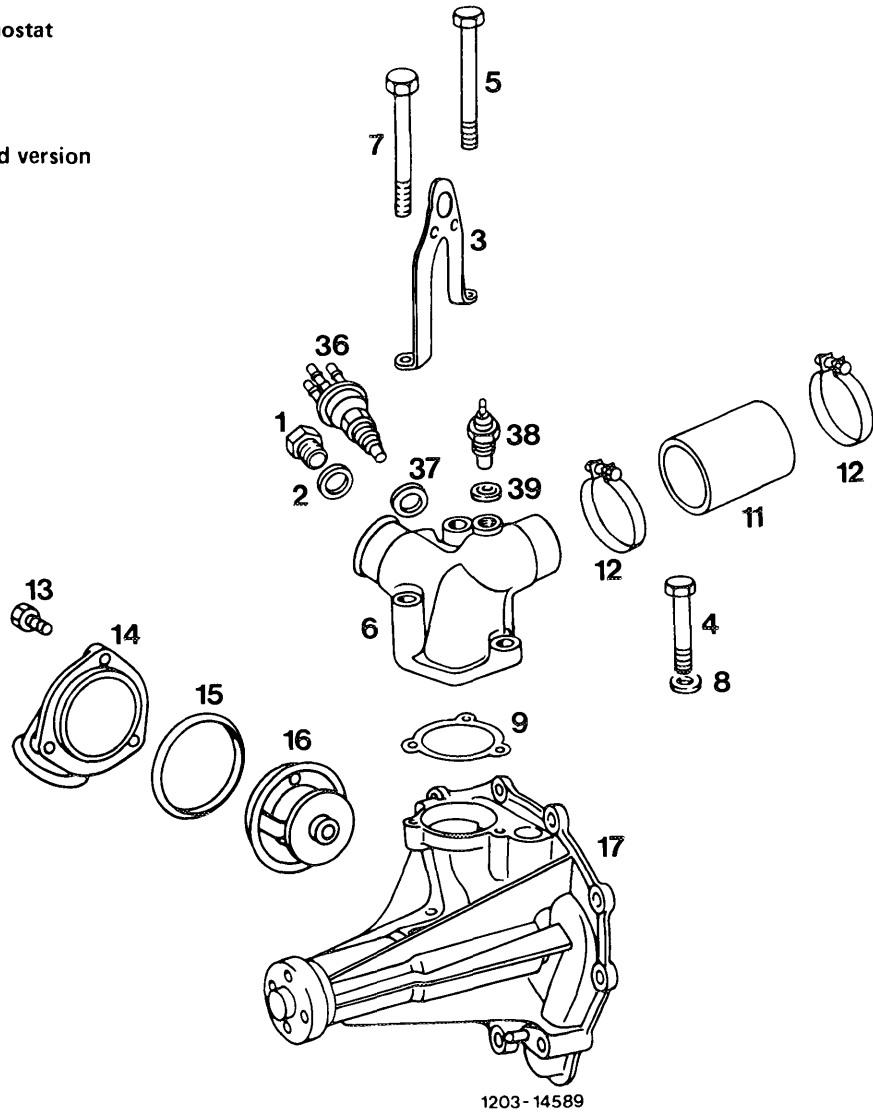

- | | | |
|----|--------------------------|--|
| 1 | Closing plug | M 14 x 1.5, vehicles without air conditioner or automatic climate control |
| 2 | Sealing ring | A 14 x 18 – DIN 7603 – AL |
| 3 | Suspension eye | |
| 4 | Hex. head bolt | M 8 x 30, tightening torque 25 Nm |
| 5 | Hex. head bolt | M 8 x 65, tightening torque 25 Nm |
| 6 | Inlet connection | |
| 7 | Hex. head bolt | M 8 x 85, tightening torque 25 Nm |
| 8 | Washer | A 8, 4, 1 each |
| 9 | Gasket | Check, renew if required |
| 11 | Coolant hose | 42 x 51 x 40 |
| 12 | Hose clamp | L 45–35, 2 each |
| 13 | Combination screw | M 6 x 20, 3 each, tightening torque 10 Nm |
| 14 | Cover coolant thermostat | |
| 15 | Sealing ring | Check, renew if required |
| 16 | Coolant thermostat | Start of control 80^{+2}_{-2} °C, end of control (fully opened) max. 94 °C. Ensure correct installation position |
| 36 | Temperature switch | On: 110^{+2}_{-3} °C, Off: 105 ± 3 °C. Switches second stage supplementary fan on vehicles with air conditioner or automatic climate control |
| 37 | Sealing ring | A 14 x 18 – DIN 7603 – AL |
| 38 | Temperature transmitter | For coolant temperature indication in instrument cluster
Installed in the right-hand cylinder head up to the end of 1980 |
| 39 | Sealing ring | A 14 x 18 – DIN 7603 – AL |

Tightening torques		Nm	
Fastening screws	Cover coolant thermostat	Engines 116.960 and 116.961 standard version 117.960, 117.961	10
	Inlet connection	Engines 116.960 and 116.961 national versions AUS J S USA 1981 116.962, 116.963, 117.962, 117.963	25
Drain plug radiator	Model 107		8
	Model 126		1.5–2 ¹⁾

¹⁾ This torque can be generated with a washer or coin.

Special tools

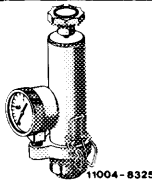
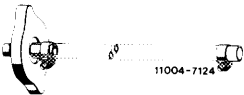
Tester for cooling system		001 589 48 21 00
Radiator cap with hose for tester		605 589 00 25 00

Conventional tool

7 mm socket insert on flexible shaft
for hose clamps with worm drive

e.g. Hazet, D–5630 Remscheid
Order No. 426–7

Note

For a more accurate indication of coolant temperature, the temperature transmitter has been moved from right-hand cylinder head into the inlet connection above the coolant pump.

Subsequent conversion on older vehicles is possible. For this purpose, install inlet connection 117 201 12 30. The existing electrical line from the temperature sensor to the coolant temperature indication in the instrument cluster can be used without change.

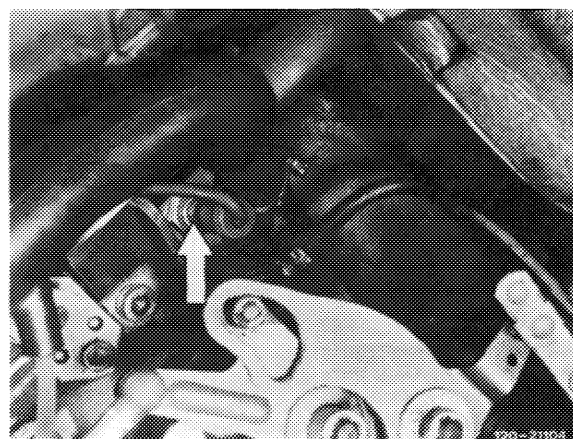

Previous installation position temperature transmitter (arrow)

Current installation position temperature transmitter (arrow)

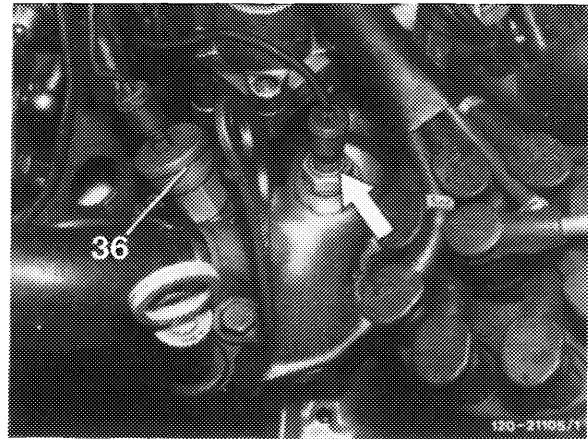

Removal

- 1 Drain coolant (20-010).

Engines 116.960, 116.961 standard version, 116.964, 116.965, 117.960, 117.961, 117.964, 117.965, 117.967 and 117.968

- 2 Disconnect coolant hose from cover (14).
- 3 Remove cover (14) and coolant thermostat.

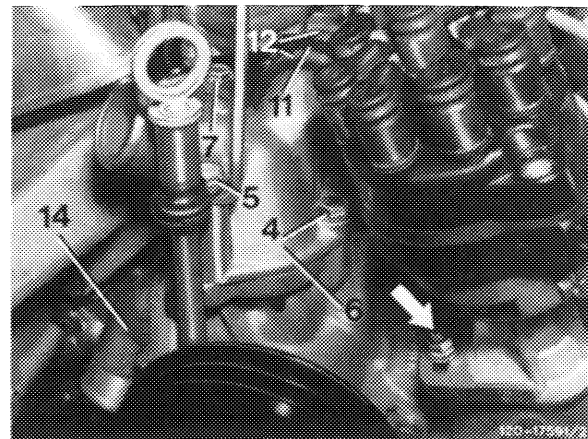

Engines 116.960 and 116.961 national versions

(AUS) (J) (S) (USA) 1981

116.962, 116.963, 117.962, 117.963

- 4 Pull off single plug of electric lines on temperature switch (3) and on temperature transmitter (5).
- 5 Disconnect vent hose on connecting pipe (arrow). (Not required on engines 116.960 and 116.961)
- 6 Loosen hose clamp (10), unscrew fastening screws (1) and remove inlet connection (8) together with coolant thermostat.

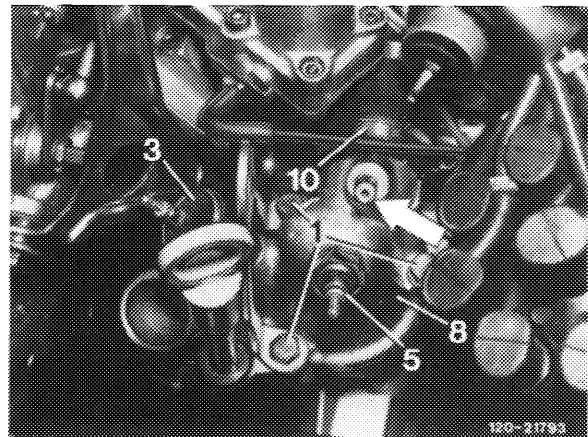

Installation

Engines 116.960, 116.961 standard version, 116.964, 116.965, 117.960, 117.961, 117.964, 117.965, 117.967 and 117.968

- 7 If required, install coolant thermostat (16) with a new sealing ring (15) in such a manner that the ball valve is on the top (arrow). During installation, ensure free movement of the ball in the valve.

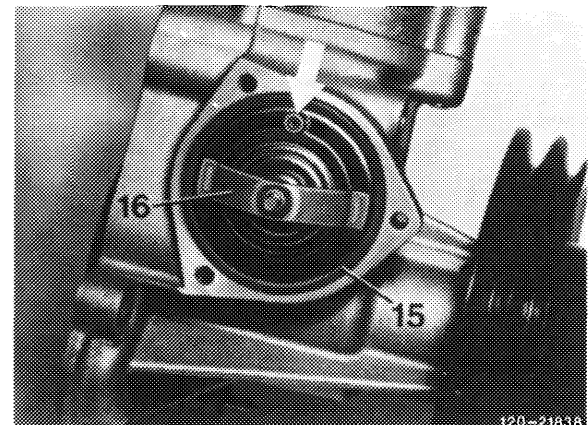

8 Install cover (14) and tighten fastening screws (13) to 10 Nm.

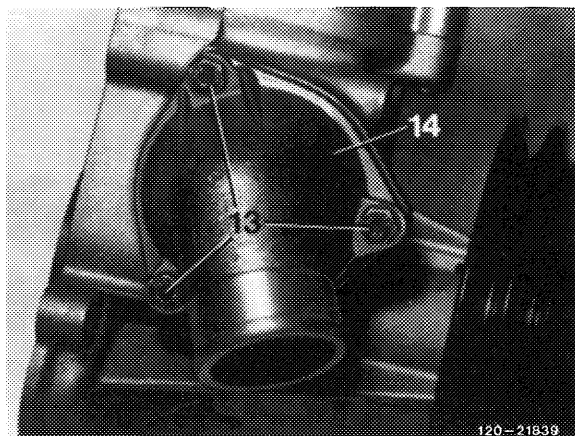

Engines 116.960 and 116.961 national versions

AUS J S USA 1981

116.962, 116.963, 117.962, 117.963

9 If required, fit new gasket (16) to coolant thermostat. Install coolant thermostat in inlet connection (8) in such a way that the lever (50) engages with pin (51) in the recess (arrow) and that the two ends of the spring (52) engage in the retaining lugs (dashed arrows).

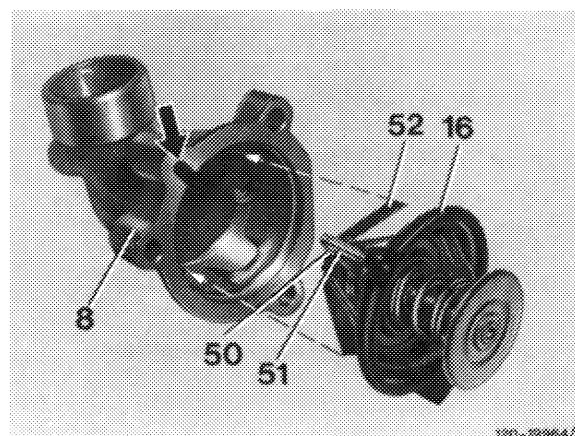

10 Install inlet connection with installed coolant thermostat in such a manner that the pin (51) engages in the control bore in the cooling pump housing (dashed arrow).

Tighten fastening screws for inlet connection to 25 Nm.

11 Refit single plug of electric lines to temperature switch and temperature transmitter and connect vent hose.

12 Fill in coolant (20-010).

13 Check cooling system for leaks by pressure-testing with tester (1 bar gauge pressure).

