

01-210 Removal and installation of timing housing cover

Tightening torques	Nm
Screw to crankshaft	270-330
Screws of pulley to hub	30

Special tools

Detent (starter removed)

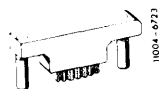

116 589 01 40 00

Torque wrench 3/4" square,
150-500 Nm



001 589 31 21 00

Socket 1/2" square, 27 mm

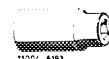

001 589 65 09 00

Allen wrench 6 mm, 440 mm long

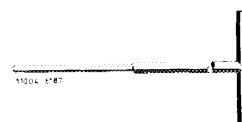

116 589 03 07 00

Inserted bushing for radial sealing ring



110 589 07 61 00

Knocking-in tool for oil dipstick guide tube

117 589 00 31 00

Conventional tool

Connection 3/4" square socket to 1/2" square head

e.g. made by Hazet, D-5630 Remscheid
order No. 1058 RI

Note

Timing housing covers differ by the number on casting and by their height.

The timing housing cover can be removed with cylinder heads mounted.

Removal

- 1 Disconnect grounding line on battery.
- 2 Drain engine oil and coolant.
- 3 Remove radiator and fan (without viscofan coupling).

4 Remove alternator with mounting bracket and ignition distributor.

5 Remove air compressor, refrigerant compressor and vacuum pump (USA).

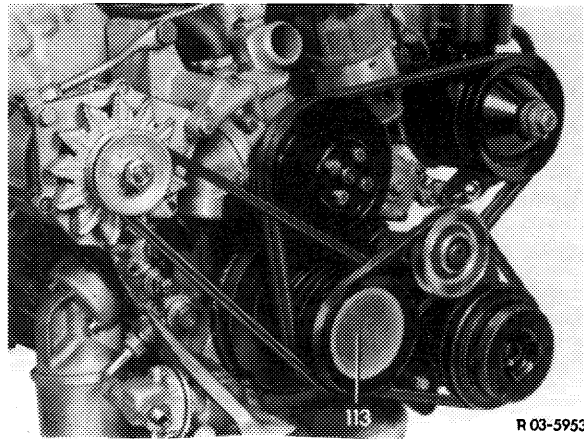

6 Remove power steering pump at connected lines and put aside.

7 Unscrew mounting bracket of power steering pump.

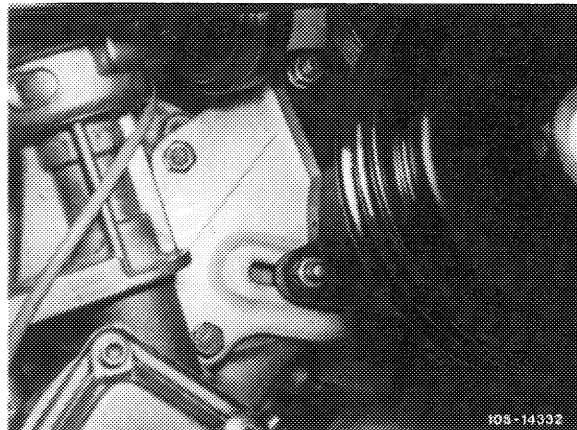

8 Remove pulley together with vibration damper and hub (03-340).

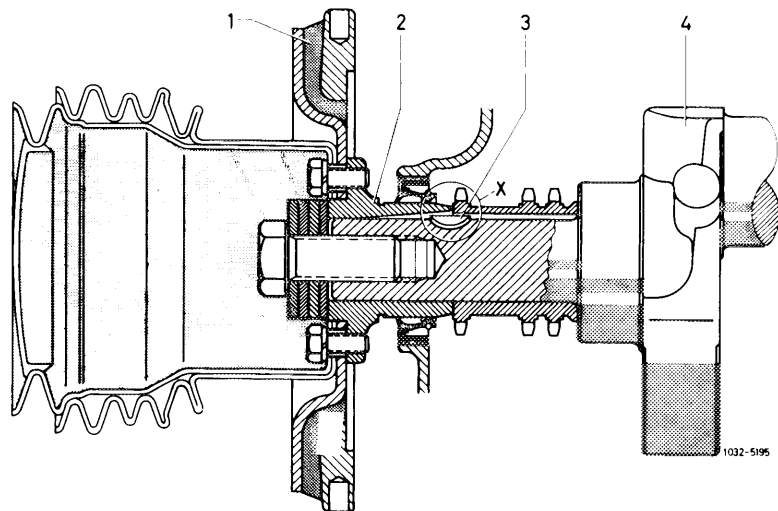
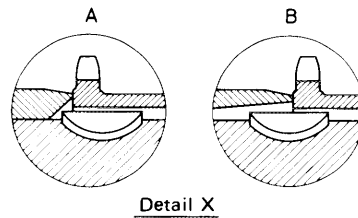

9 Remove oil damper with holder.

Do not unscrew closing plugs (arrows).

On engines with oil suction, remove oil dip stick guide tube.

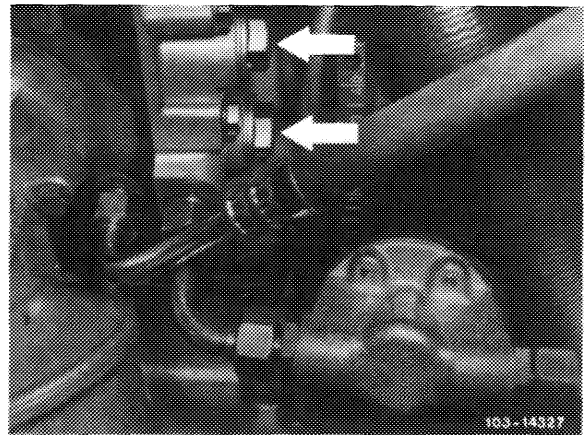

10 Remove coolant pump with housing (20–210).

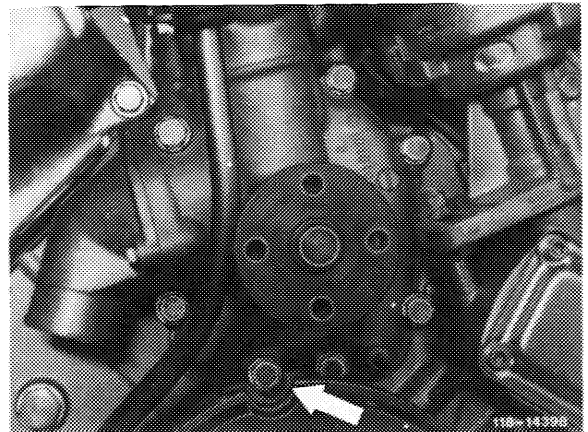

11 Remove oil pump (18–210). Loosen oil pan upper half on two-piece oil pan on crankcase, that is, loosen screws for approx. 3–4 turns.

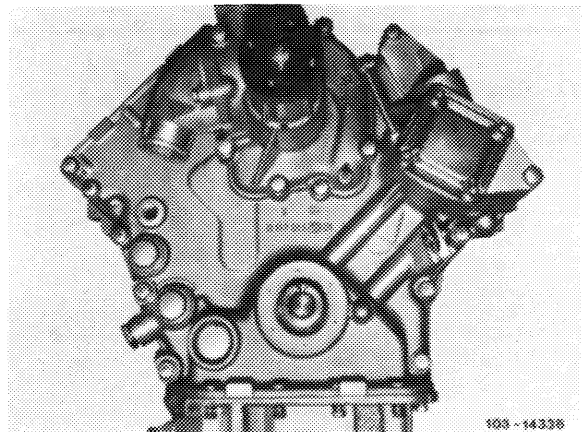

12 Unscrew cylinder head bolts M 8 (arrows).

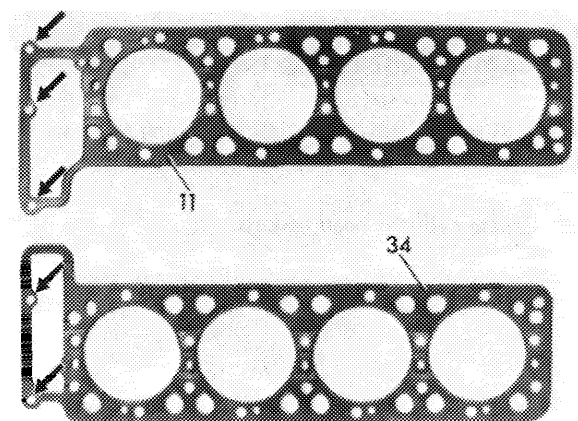

R 01/6175

- 13 Disconnect TDC transmitter and pull out.
- 14 Unscrew all screws for timing housing cover.

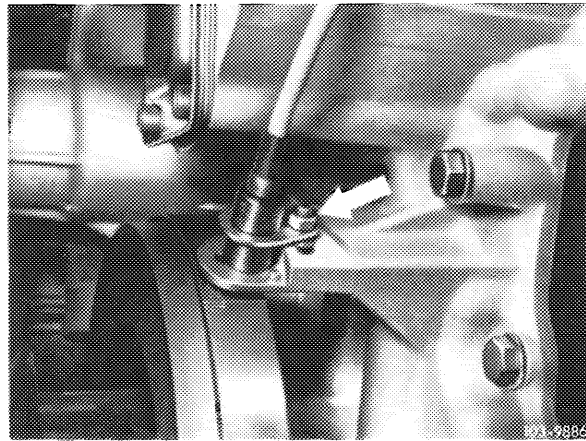

- 15 Push out radial sealing ring for crankshaft.
- 16 Remove timing housing cover while disconnecting oil pump chain on crankshaft sprocket.

Attention!
Do not damage cylinder head gasket.
Renew damaged cylinder head gaskets.

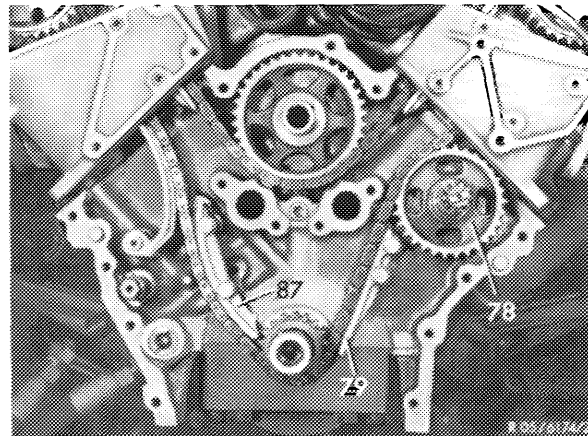

Installation

- 17 Renew O-rings for sealing coolant ducts.

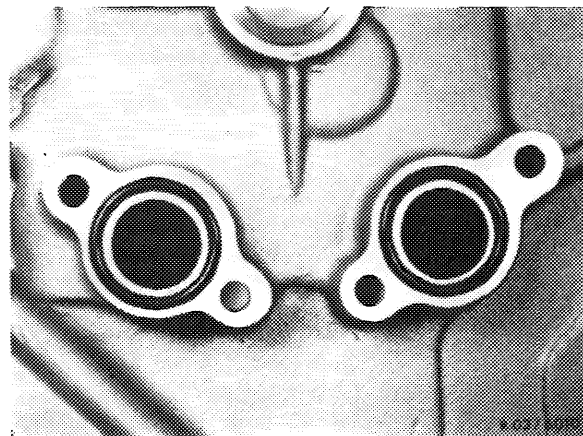

Attention!
If the bearing bushings are renewed, pay attention to position of bottom oil groove (arrows).

- 18 Coat sealing surface of timing housing cover with sealing compound.
- 19 Grease cylinder head gaskets.

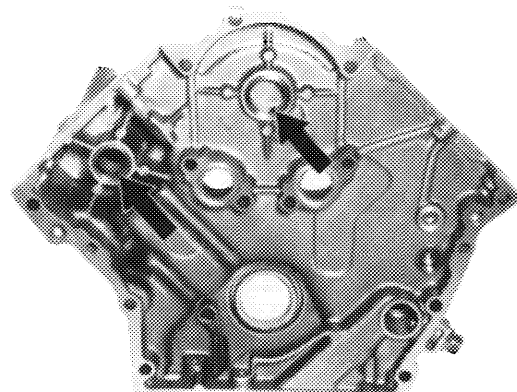

20 When mounting timing housing cover, place oil pump chain with a curved panel on crankshaft sprocket.

21 Screw-on cylinder head bolts M 8 first.

22 For further installation proceed vice versa.

- 1 Timing housing cover
- 2 Threaded bolts for adjusting lever of ignition distributor
- 3 Holder for engine shock absorber
- 4 Screw M 8 x 45 (10 each)
- 5 Washer A 8.4
- 6 Bearing bushing guide wheel
- 7 Closing plug
- 8 Sealing ring
- 9 Closing plug M 26 x 1.5
- 10 Sealing ring
- 11 End cover
- 12 Gasket
- 13 Combination screw 6 x 15
- 14 Screw connection
- 15 Sealing ring
- 16 Closing plug M 26 x 1.5
- 17 Sealing ring
- 18 Bearing bushing for intermediate sprocket shaft
- 19 Screw M 8 x 105
- 20 Washer
- 21 Screw M 8 x 25
- 22 Washer
- 23 Radial sealing ring
- 24 Spring washer
- 25 Bearing bolt

