

22–240 Removal and installation of engine shock absorber

Tightening torque

Nm

Engine shock absorber attachment, hex. nut M 6

8–12

Note

For loosening and tightening the lower hex. nut apply counterhold to piston rod at flats (arrows) for wrench provided for this purpose.

Observe tightening torque 8–12 Nm, do not pull against the block.

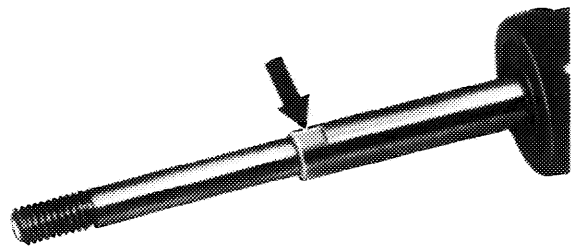

A. Model 107

100–13098

Engine shock absorber left and right

- 1 Remove expansion tank for removing the right-hand engine shock absorber.
- 2 Remove the pressure regulator to permit removal of the left-hand engine shock absorber.
- 3 Unscrew engine fastening screw from engine mount and unscrew engine shock absorber.
- 4 Remove engine shock absorber together with bracket.

Caution!

During installation observe location of rubber buffers and cup washers (22–211).

Engine shock absorber left seen from the front

- | | |
|----------------------------|------------------------------------|
| 1 Nut M 6 | 6 Bracket on side member |
| 2 Washer A 7.4 | 7 Engine shock absorber, L = 45 mm |
| 3 Cup washer 43 mm dia. | 8 Cup washer 30 mm dia. |
| 4 Rubber buffer 36 mm dia. | 9 Rubber buffer 26 mm dia. |
| 5 Shielding plate | 10 Bracket left |

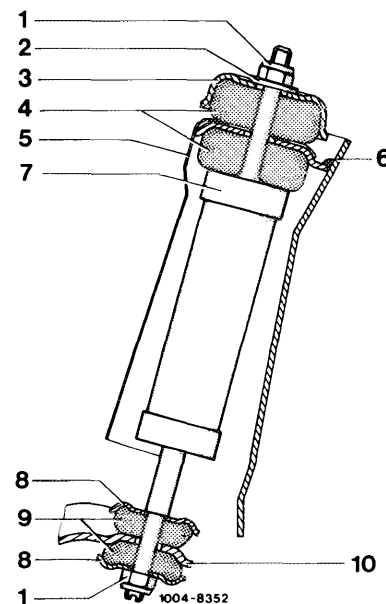

B. Model 126

Engine shock absorber left and right

During installation, observe location of rubber buffers and cup washers.

Engine shock absorber and layout are the same at the left and right.

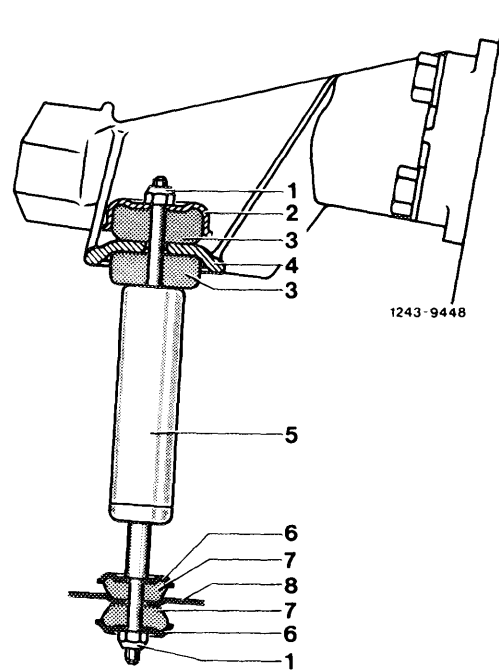

Engine shock absorber right seen from the front