

B. Delco-refrigerant compressor (engines 116 and 117)

Data



Designation	Delco, 6-cylinder swashplate compressor, 206.5 cc, model no. 59 10 763		
Max. speed	1/min		6400
Required input at max. compressor speed	kw(HP)		approx. 6.3 (8.5)

Oil filling capacity

Oil grade refrigerant oil (for approved refrigerant oils refer to specifications for service products, page 362)			
Oil quantity with new refrigerant compressor		in cc	300
Oil quantity with refrigerant compressor removed and air conditioning system flushed with R 11		in cc	300
Oil quantity with rerrigerant compressor removed and air conditioning system not flushed		in cc	200

Tightening torques		Nm	(kpm)
Suction hose on pipe line	with Cu seal	60 ± 5	(6.0 ± 0.5)
	without Cu seal	70 ± 5	(7.0 ± 0.5)
Pressure hose on pipe line	with Cu seal	45 ± 5	(4.5 ± 0.5)
	without Cu seal	55 ± 5	(5.5 ± 0.5)
Pipe line to refrigerant compressor		17	(1.7)
Oil check plug		15–17	(1.5–1.7)
8 mm screws		35	(3.5)
10 mm screws		30–35	(3.0–3.5)
12 mm screws		40–45	(4.0–4.5)
Hex nuts on threaded bolt		25–30	(2.5–3.0)

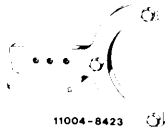
Special tools

Holding device for refrigerant compressor	 11004-8423	109 589 00 31 00
Support for inner mechanism	 11004-8438	109 589 01 31 00
Pressure test plate	 11004-7632	109 589 00 25 00

Conventional tool

Double open-end wrench 3/8" x 7/16" for oil check plug

Removal

1 Remove refrigerant compressor and clean outside surfaces (83–522).

2 Unscrew oil check plug (3) and drain all the refrigerant oil in compressor.

To accelerate draining of refrigerant oil, rotate drive shaft several times. **Do not use drained refrigerant oil again** (83–520).

3 Remove spring plate, pulley, clutch coupler and shaft seal (83–526).

4 Turn compressor around in holding device, with front end down. Unscrew hex nuts on compressor housing and remove rear head member. If head member is stuck, apply uniform blows against head member with a rubber hammer.

Removal of rear exhaust valve plate

- 1 Exhaust valve plate
- 2 Spring holder
- 3 Exhaust valve

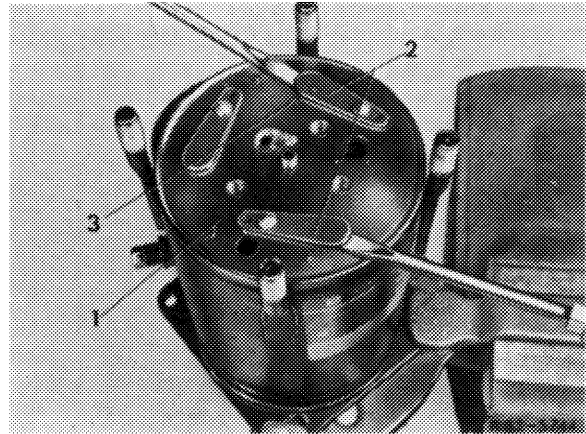

5 Wipe refrigerant oil from sealing surface of rear head member and check surfaces. In the event of damage, replace head member.

- 1 Head member rear
- 2 Sealing surface

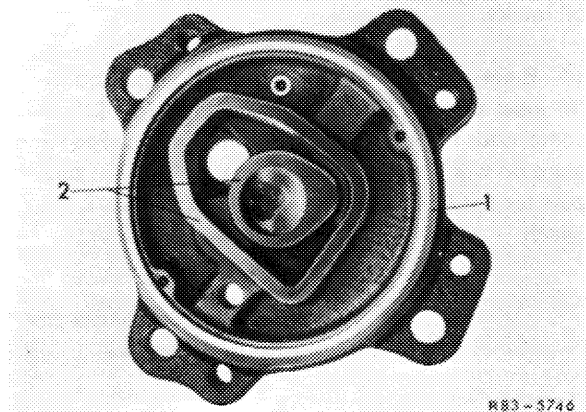

6 Remove suction strainer, check and clean, if required.

7 Apply an identification to outer surface of inner and outer oil pump gear wheel. Then remove gears.

8 Remove sealing ring between head member and housing.

- 1 Inner gear wheel
- 2 Outer gear wheel
- 3 Sealing ring

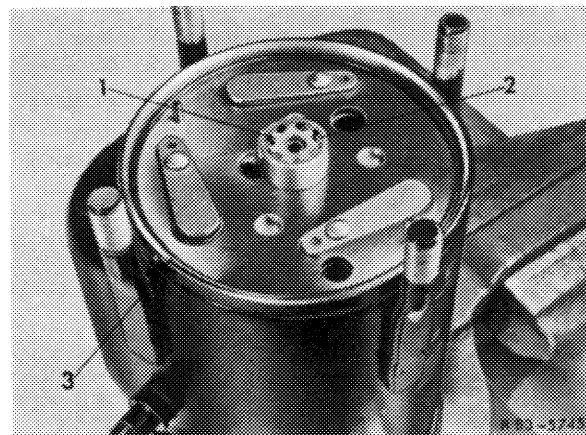

9 Carefully remove rear valve plates by positioning two screwdrivers under spring holders — not between spring and spring seat — and force out valve plates.

10 Check valve springs and valve seats. In the event of damage, renew entire valve plate.

Removal of rear exhaust valve plate

- 1 Exhaust valve plate
- 2 Spring holder
- 3 Exhaust valve

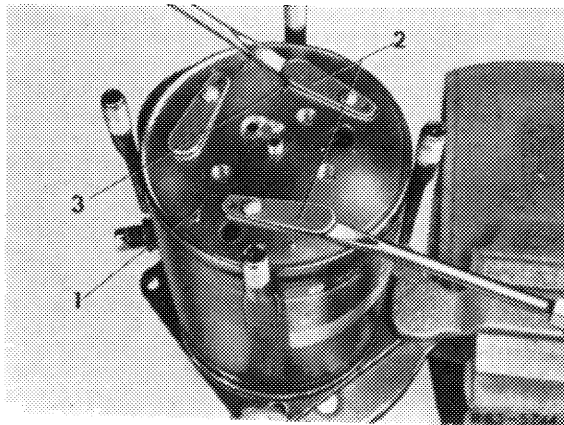

11 Lift-out rear intake valve plate by means of two screwdrivers, but do not apply force against leaf spring valves.

12 Check leaf springs of valve plate for damage and replace, if required.

Removal of rear intake valve plate

- 1 Intake valve plate

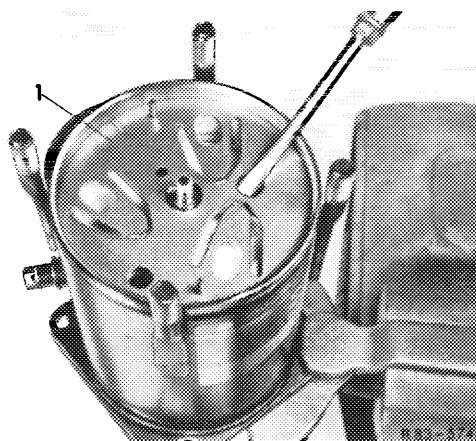

13 Remove oil intake pipe (1) and sealing ring from oil intake.

14 Release compressor from holder, place support for inner assembly group over oil pump shaft. Lift compressor from holder. Turn compressor around and place on work bench in such a manner that the support for the inner assembly group rests on work bench.

Removal of oil intake pipe

- 1 Oil intake pipe
- 2 O-ring
- 3 Removing tool

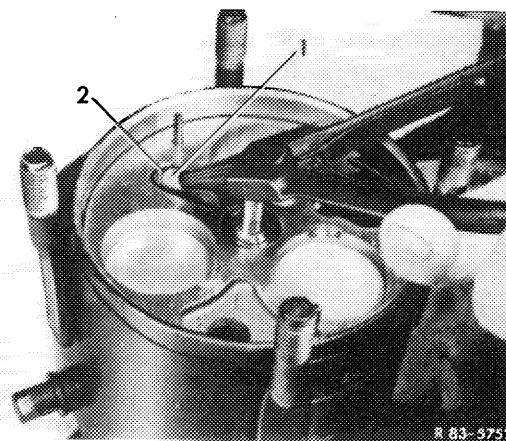

15 Lift off front head member and compressor housing. The inner mechanism remains on support.

Attention! Do not knock against end of compressor shaft when pushing out inner mechanism. If inner mechanism is not slipping out of compressor housing, blow with a plastic hammer against front head member.

16 Place compressor housing with front head member on side and knock head member out through compressor housing, making sure that the sealing surfaces on inside of front head member are not damaged.

17 Wipe refrigerant oil from sealing surface of front head member and inspect sealing surface. If damage shows up, replace head member.

18 Remove front exhaust and intake valve plate. Inspect leaf springs and their seats. Replace these parts, if required.

19 Check inner mechanism for damage. If damage is essential (e.g. seized cylinder liner) caused by a shortage of refrigerant or oil, a complete exchange or a new refrigerant compressor is recommended.

Installation

20 Place inner mechanism on support.

21 Insert new guide pins (2) into front cylinder half, if previously removed.

22 Mount front intake valve plate (1) on front cylinder half. Align oil return slot and overflow pipe with guide pins (2).

Installation of front intake valve plate

- | | |
|----------------------|-------------------|
| 1 Intake valve plate | 3 Oil return slot |
| 2 Guide pins | 4 Overflow pipe |

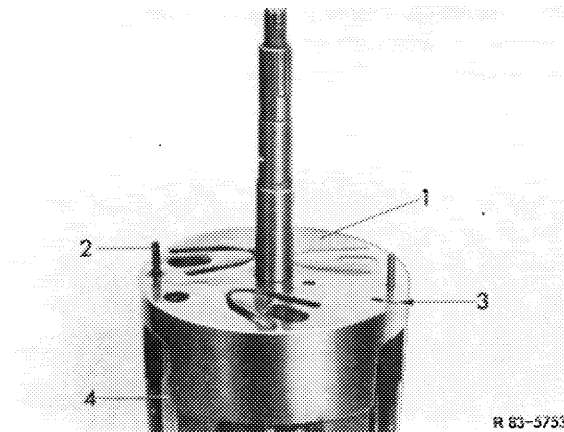

23 Install front exhaust valve plate while aligning bores in valve plate with guide pins.

Installation of front exhaust valve plate

- | | |
|-----------------------|-------------|
| 1 Exhaust valve plate | 2 Guide pin |
|-----------------------|-------------|

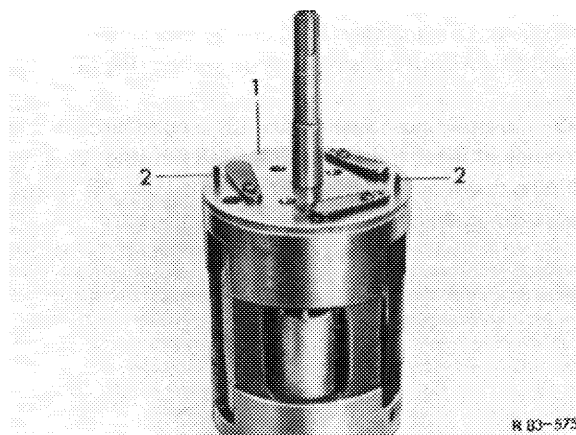

Note: The front exhaust valve plate (1) is recognized by a large diameter hole in center of plate.

24 Coat sealing surface on ribs of front head member with refrigerant oil.

- 1 Intake valve plate
- 2 Exhaust valve plate rear
- 3 Exhaust valve plate front

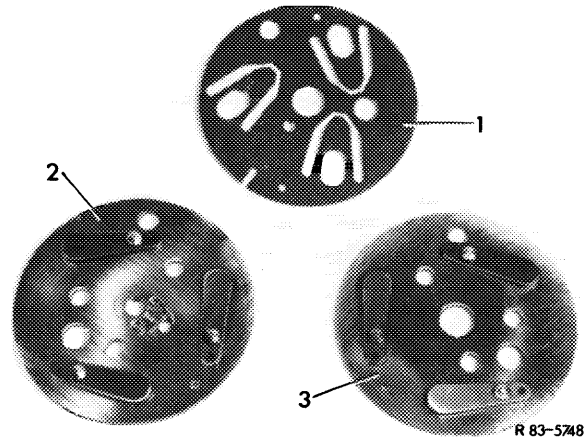

25 Determine position of head member (1) in relation to guide pins (2) on inner assembly group. Mark location of bores on outside of front head member. Place front head member carefully into correct position, while making sure that the sealing surfaces around center bore of head member are not touching shaft (3) when the head member (1) is lowered. In addition, do not rotate head member to engage the guide pins, since this would result in the sealing surfaces touching the valve bores.

- Installation of front head member
- 1 Head member front
 - 2 Exhaust valve plate
 - 3 Shaft

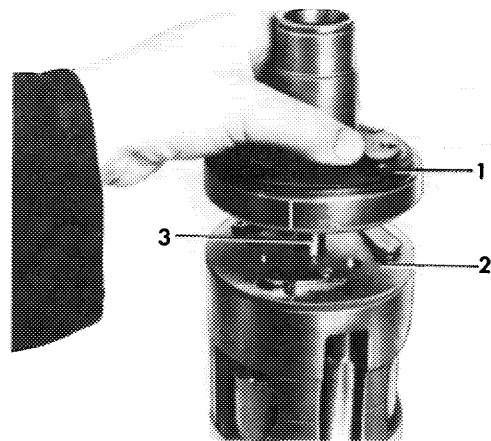

26 Provide chamfered groove on lower end of head member (1) well with refrigerant oil and insert a new sealing ring (2) into groove.

- 1 Head member front
- 2 Sealing ring

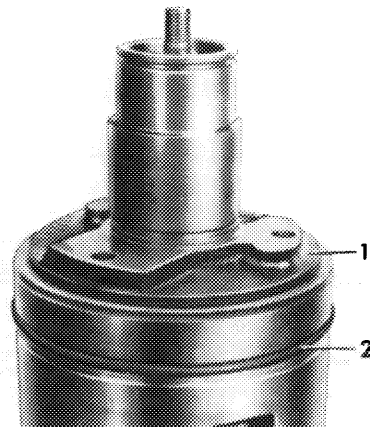

27 Coat inner surface of compressor housing with refrigerant oil and then slip housing over inner mechanism until housing rests on sealing ring (3).

28 Carefully push sealing ring (3) around circumference of inner mechanism (2) until housing (2) is sliding down over mechanism. Align oil pan (4) with bore (5) when housing is sliding down.

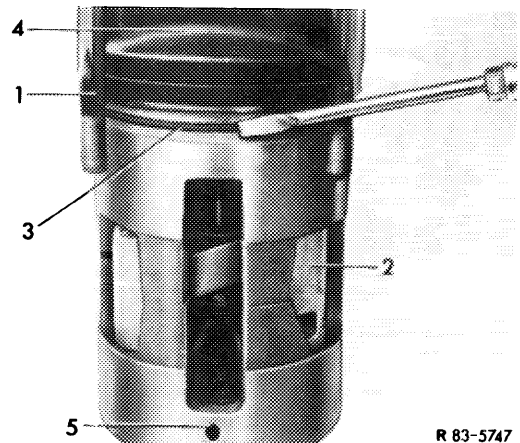

29 Hold support in position, turn compressor around and install into holding fixture. Then remove support.

30 Insert new guide pins into rear cylinder half, if previously removed.

31 Insert new sealing ring into bore for oil intake pipe.

- 1 Exhaust valve plate
- 2 Spring holder
- 3 Exhaust valve

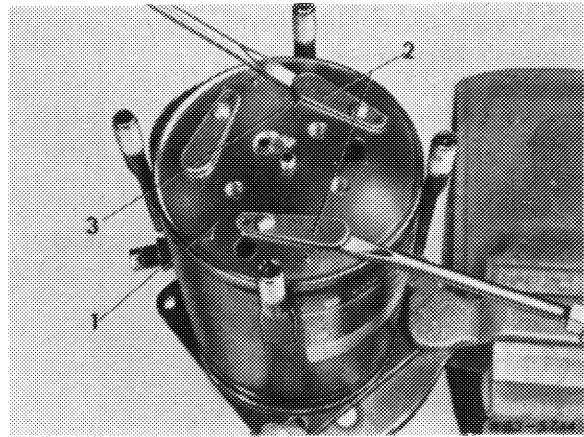

32 Provide oil intake pipe with cold-flowing oil and install, while turning compressor mechanism until oil intake pipe (1) is in alignment with hole in housing wall.

- Removal of oil intake pipe
- 1 Oil intake pipe
 - 2 O-ring
 - 3 Removing tool

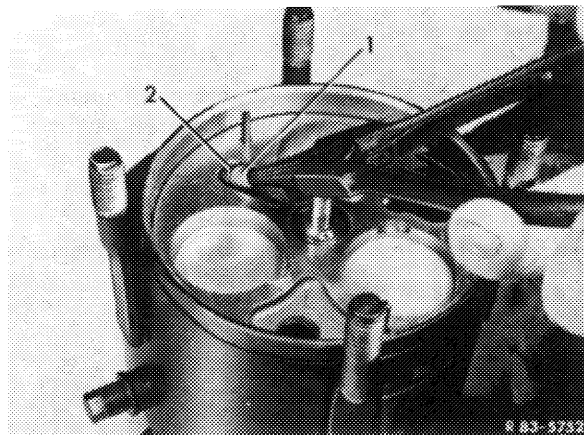

33 Insert rear intake valve plate over guide pins with oil return slot in direction of oil pan.

- Installation of rear intake valve plate
- 1 Intake valve plate

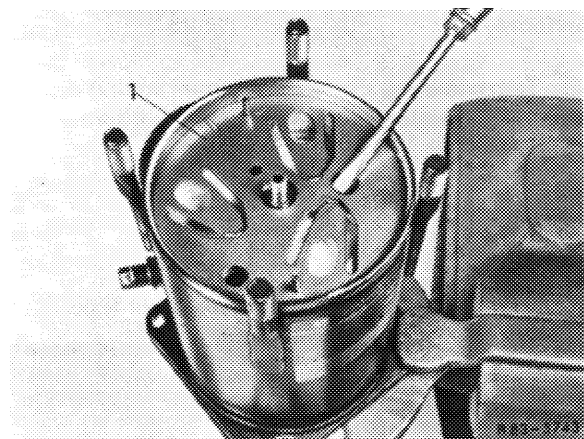

34 Install rear exhaust valve plate over guide pins.

35 Slip inner oil pump gear wheel (1) on shaft so that the previously applied identification is pointing upwards.

36 Slip outer oil pump gear wheel (2) over inner gear wheel (1), with the previously applied identification in upward direction.

- 1 Inner gear wheel
- 2 Outer gear wheel
- 3 Sealing ring

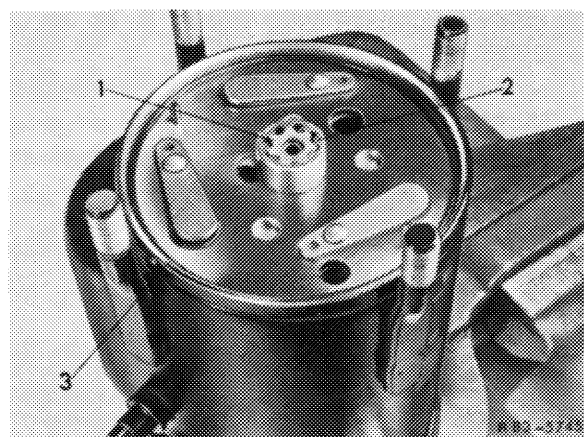

37 Provide complete rear exhaust valve plate and around outer diameter between housing and valve plate with refrigerant oil.

38 Provide the new sealing ring (3) between head member and housing with refrigerant oil and place on exhaust valve plate or into housing.

39 Carefully insert suction strainer into rear head member.

Caution! Do not damage.

40 Provide sealing surfaces on ribs of head member with refrigerant oil.

41 Slip rear head member over stud, making sure that the strainer is not falling out of its seat and that the teflon seal is not damaged.

Note: If the rear head member is not engaging in guide pins, turn front head member and push manually.

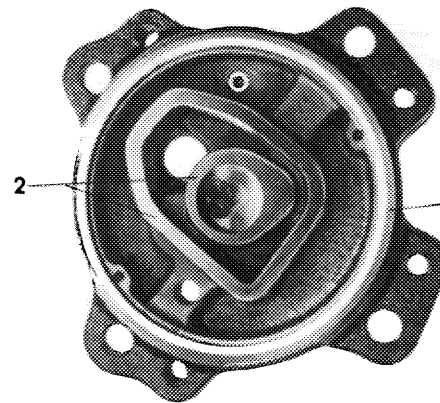

1 Head member rear
2 Sealing surface

R83-5746

42 Screw hex nuts on threaded bolt and tighten uniformly.

43 Turn compressor in holding fixture around and install shaft seal, clutch coupler, pulley and spring plate (83-526).

44 Fill new refrigerant oil into compressor (83-520).

45 Check Delco-refrigerant compressor for leaks (83-525).

Components of Delco-refrigerant compressor

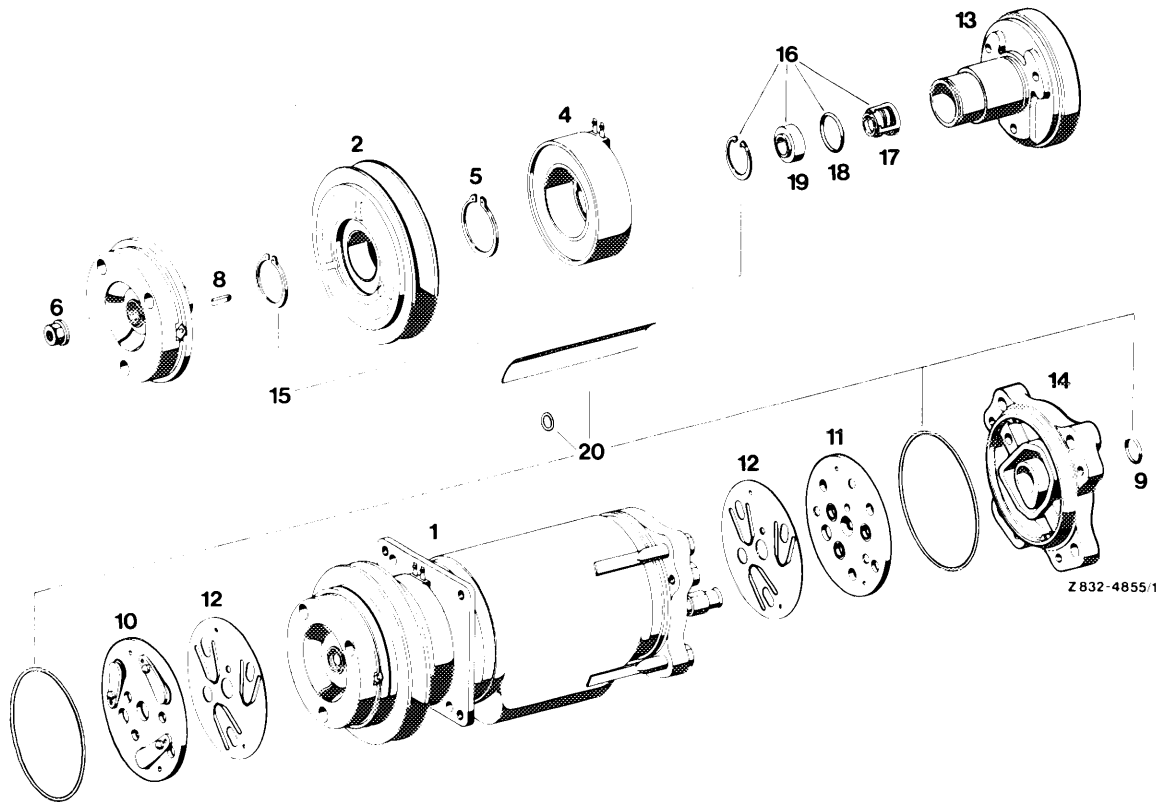

Z 832-4855/1

- | | | | | | |
|---|-----------------------------------|----|---------------------------|----|--------------------|
| 1 | Frigidaire refrigerant compressor | 8 | Key | 15 | Locking ring (set) |
| 2 | Pulley | 9 | O-ring | 16 | Sealing assembly |
| 3 | Spring plate | 10 | Exhaust valve plate front | 17 | Shaft seal |
| 4 | Clutch coupler | 11 | Exhaust valve plate rear | 18 | O-ring |
| 5 | Locking ring | 12 | Inake valve plate | 19 | Ceramic ring |
| 6 | Counternut | 13 | Head member front | 20 | Sealing assembly |
| 7 | Spacing washer | 14 | Head member rear | | |