

A. Model 115.1

Oil circuit

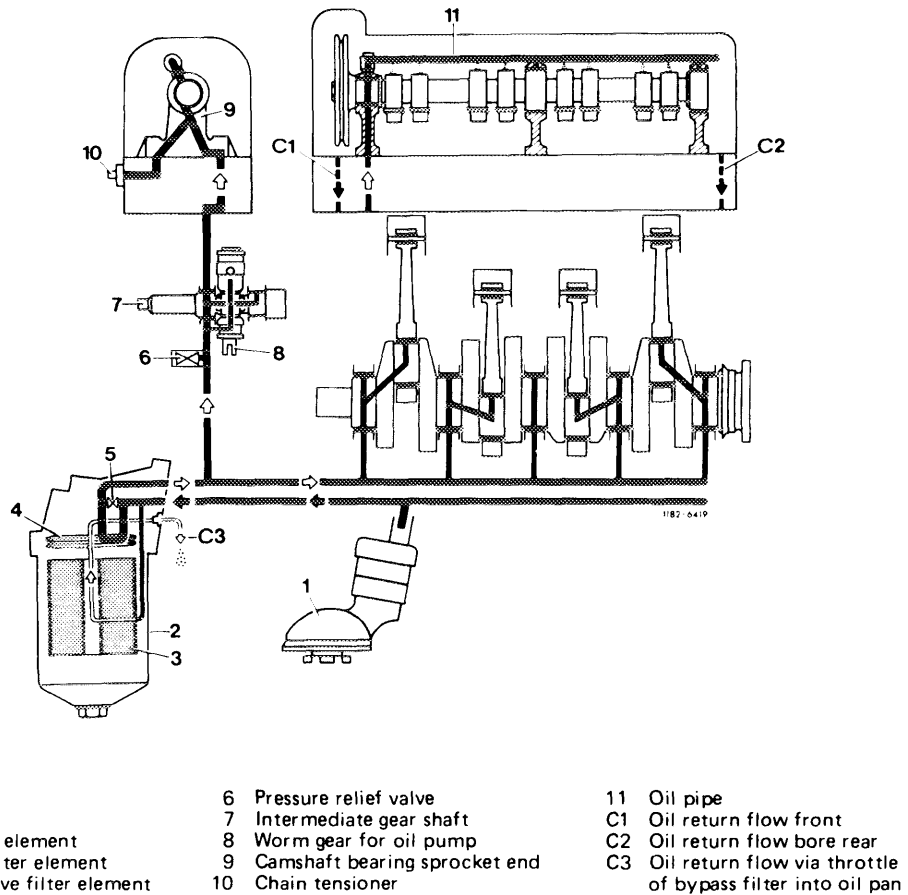

- |                                 |                                 |   |
|---------------------------------|---------------------------------|---|
| 1 Oil pump                      | 6 Pressure relief valve         | 11 Oil pipe   |
| 2 Oil filter                    | 7 Intermediate gear shaft       | C1 Oil return flow front                                      |
| 3 Bypass filter element         | 8 Worm gear for oil pump        | C2 Oil return flow bore rear                                  |
| 4 Main flow filter element      | 9 Camshaft bearing sprocket end | C3 Oil return flow via throttle of bypass filter into oil pan |
| 5 Overflow valve filter element | 10 Chain tensioner              |   |

Air oil cooler and thermostat in oil filter

|                                      |                          |
|--------------------------------------|--------------------------|
| Engine with air oil cooler           | thermostat in oil filter |
| 615.912 up to chassis end No. 400248 | —                        |
| 616 general                          | —                        |
| 617 general                          | general                  |

## Oil pressure

At operating temperature, the oil pressure at idle may drop to 0.5 bar gauge pressure (0.5 atü). During acceleration, the oil pressure should rise again immediately and should attain at least 3 bar gauge pressure (3 atü) at 3000/min.

| Opening pressures of pressure relief valves             | bar gauge pressure | (atü)            |
|---|--------------------|------------------|
| Bypass valve — filter element                           | 3.5                | (3.5)            |
| Bypass valve — air oil cooler                           | 1.5                | (1.5)            |
| Pressure relief valve in main oil duct front engine 615 | 5.0                | (5.0)            |
| Pressure relief valve on oil pump engine 616, 617       | 8.0 or 7.0         | (8.0 or 7.0 atü) |
| <b>Thermostat — oil filter engine 617</b>               |                    | °C               |
| Begin of opening  |                    | 95 ± 4           |
| Fully opened  |                    | 110 ± 4          |

## Pressure relief valve

On engine 615, the pressure relief valve is screwed in or on, respectively, main oil duct at engine face and on engines 616/617 at oil pump.

If there is no oil pressure or if the oil pressure is too low, check whether oil pressure relief valve on oil pump has dropped or become loose.

In both cases, coat threads of oil pressure relief valve with sealing compound, part No. 002 989 94 71 and screw-in.

## Bypass valve in oil filter

The bypass valve (11) opens when the difference in pressure between the dirty side and the clean side of filter exceeds 3.5 bar gauge pressure.

This will happen when the filter element is heavily contaminated. The oil will then flow to engine in uncleaned condition.

- 2 Closing plug with sealing ring
- 3 Connection for oil pressure gauge
- 11 Star valve (overflow valve — filter element)
- 12 Compression spring

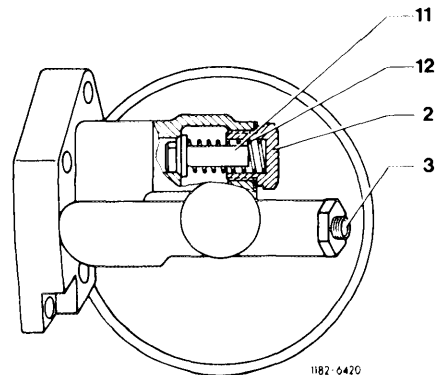

## Oil filter

The main and bypass filter elements are separately located.

During first inspection (500–1000 km), replace initial operation filter element with filter cartridge (4) and main flow filter plate element (3).

Then replace filter cartridge during oil change every 5000 km.

- 1 Filter top
- 2 Sealing ring
- 3 Main flow filter element
- 4 Bypass filter element
- 5 Compression spring with spring retainer
- 6 Filter bottom
- 7 Sealing ring
- 8 Hex. bolt

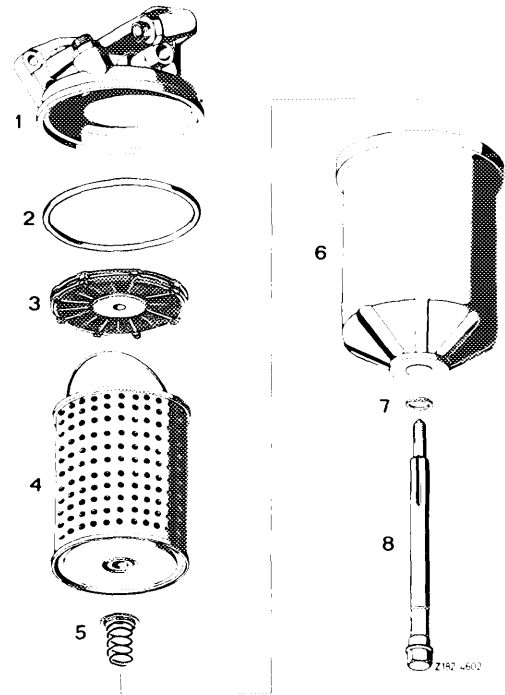

Clean main flow filter plate element with holding pliers 110 589 00 68 00 in benzine.

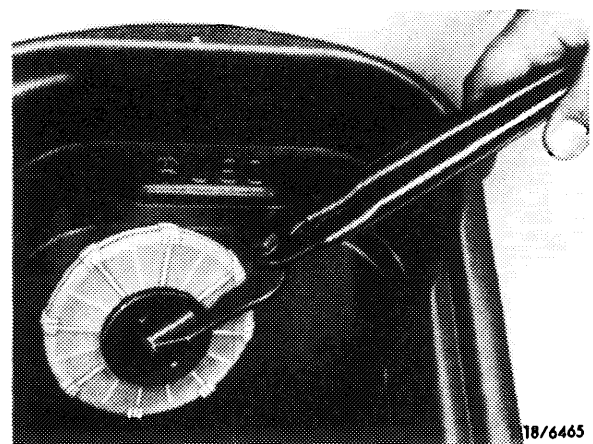

18/6465

## Operation

### Engines 615 and 616

Coming from feed duct (a), the oil flows into oil filter housing. The major portion of the oil flows through main flow filter element (4) and via duct (b) into main oil duct and to the bearing points. The remaining oil flows from outside through bypass filter element (6) where it is finely filtered and from there across a groove in hex. bolt (10) through throttle bore (d) back into oil pan.

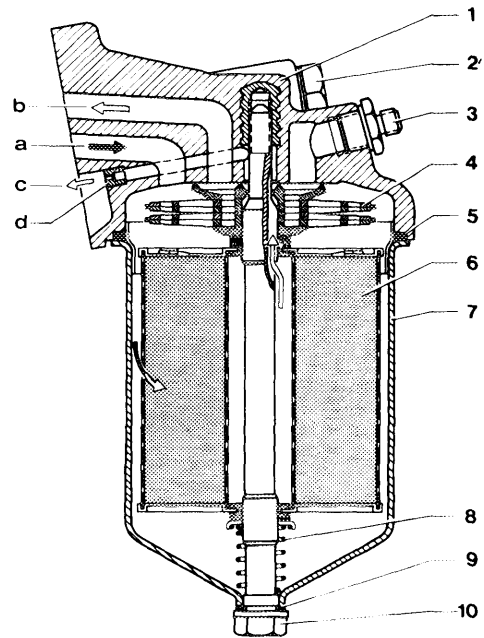

### Engine 615

- 1 Filter top
- 2 Closing plug with sealing ring
- 3 Connection for oil pressure gauge
- 4 Main flow filter element
- 5 Sealing ring
- 6 Bypass filter element
- 7 Filter bottom
- 8 Compression spring with spring retainer
- 9 Sealing ring
- 10 Hex. bolt
- 11 Star valve (overflow valve – filter element)
- 12 Compression spring
- a Uncleaned oil to filter
- b Cleaned oil to lube points
- c Cleaned oil from bypass filter element into oil pan
- d Throttle (also installed on engines 616, 617.91)

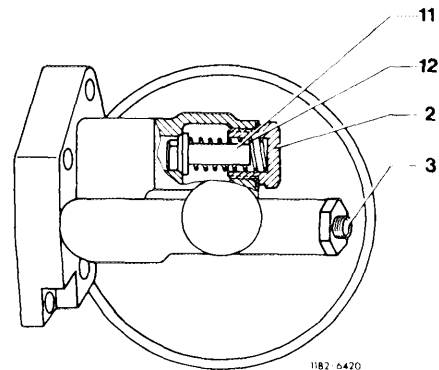

1182 0420

## Engine 616

Starting at a differential pressure of approx. 1.5–1.7 bar, the oil will flow directly to main and bypass filter element.

Below approx. 1.5–1.7 bar differential pressure, the bypass valve (11) will close. The oil will now flow via air oil cooler to main and bypass filter element.

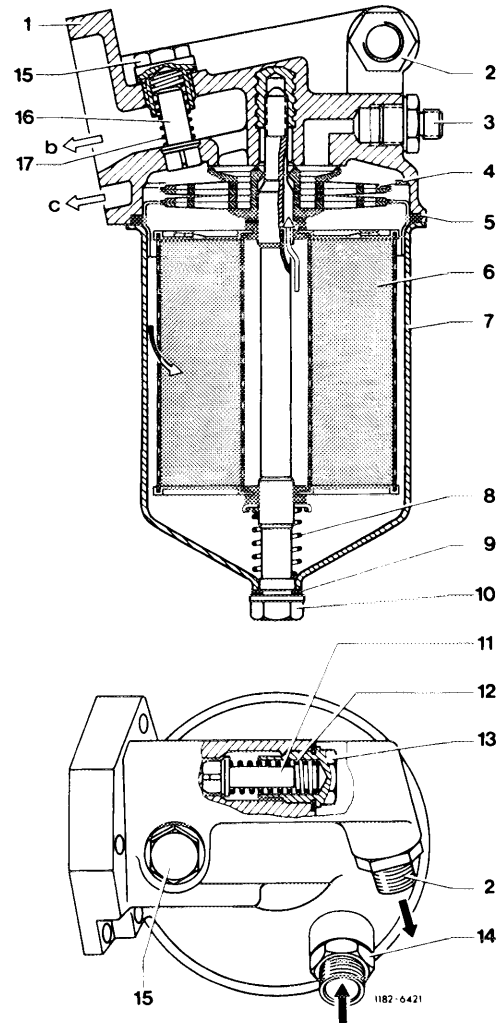

## Engine 616

- 1 Filter top
- 2 Screw connection with sealing ring (uncleaned oil to oil cooler)
- 3 Connection for oil pressure gauge
- 4 Main flow filter element
- 5 Sealing ring
- 6 Bypass filter element
- 7 Filter bottom
- 8 Compression spring with spring retainer
- 9 Sealing ring
- 10 Hex. bolt
- 11 Star valve (bypass valve – air oil cooler)
- 12 Compression spring
- 13 Closing plug with sealing ring
- 14 Screw connection with sealing ring (uncleaned oil from oil cooler)
- 15 Closing plug with sealing ring
- 16 Star valve (overflow valve – filter element)
- 17 Compression spring
- b Cleaned oil to lube points
- c Cleaned oil from bypass filter element into oil pan

## Engine 617

Starting at an oil temperature of approx. 95°C, thermostat (13) begins displacing control valve (12).

In end position, the direct flow to main or bypass filter element is closed except for a given quantity of oil.

This quantity of oil is enough to guarantee lubrication of engine at low outside temperatures when the through-flow in oil cooler is extensively prevented by the viscosity of the oil.

The major portion of the oil flows to air oil cooler and is cooled there, it will then flow back to oil filter housing and through main and bypass filter element to bearing points or oil pan.

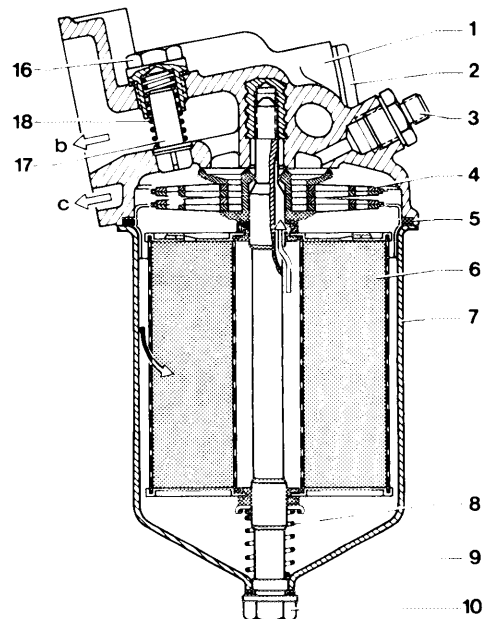

### Engine 617

- 1 Filter top
- 2 Closing plug with sealing ring
- 3 Connection for oil pressure gauge
- 4 Main flow filter element
- 5 Sealing ring
- 6 Bypass filter element
- 7 Filter bottom
- 8 Compression spring with spring retainer
- 9 Sealing ring
- 10 Hex. screw
- 11 Compression spring
- 12 Control valve
- 13 Thermostat
- 14 Screw connection with sealing ring (uncleaned oil to oil cooler)
- 15 Screw connection with sealing ring (uncleaned oil from oil cooler)
- 16 Closing plug with sealing ring
- 17 Star valve (overflow valve – filter element)
- 18 Compression spring
- b Cleaned oil to lube points
- c Cleaned oil from bypass filter element into oil pan

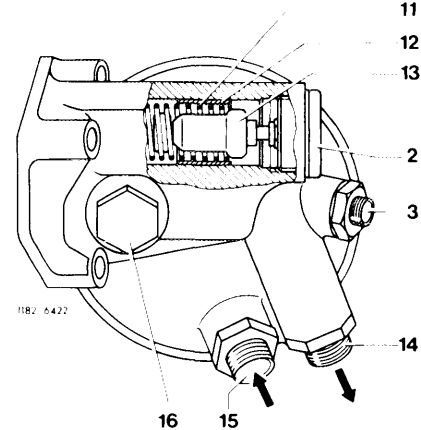

When the filter element is badly contaminated and the differential pressure between the dirty and the clean side of the filter exceeds 3.5 bar gauge pressure, the bypass valve (17) will open. The oil will then flow to engine in uncleaned condition.

B. Model 123.1

Oil circuit

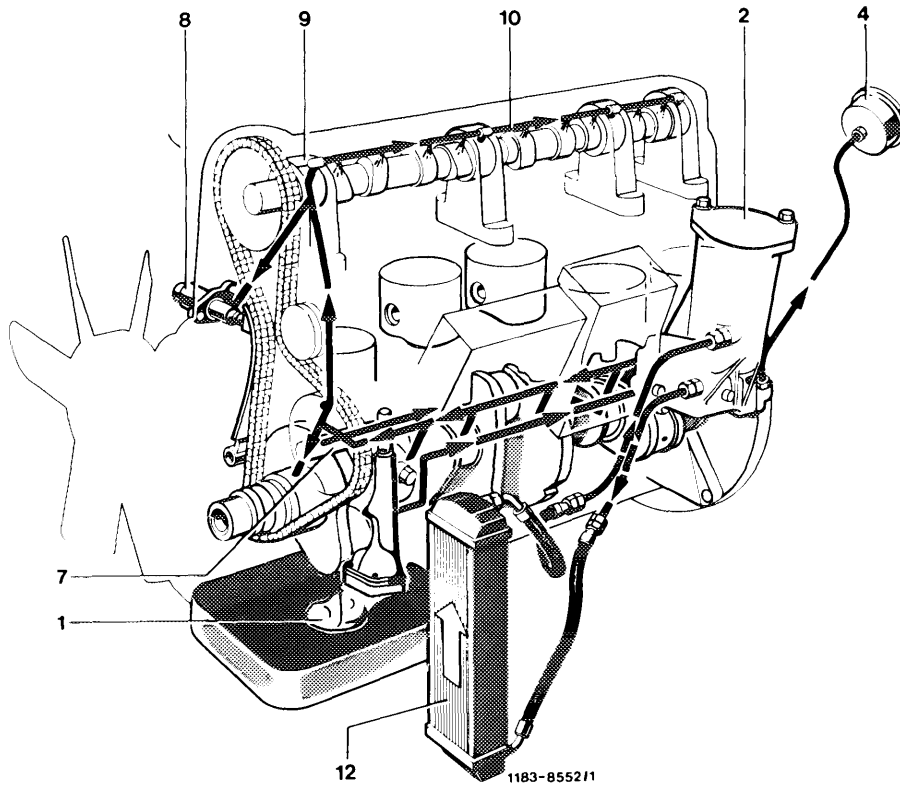

- |  |                                 |
|--|---------------------------------|
| 1 Oil pump with screwed-on pressure relief valve | 8 Chain tensioner               |
| 2 Oil filter                                     | 9 Camshaft bearing sprocket end |
| 4 Pressure gauge                                 | 10 Oil pipe                     |
| 7 Intermediate gear shaft                        | 12 Air oil cooler               |

On engines 616.912, starting February 1979, on vehicles with air conditioning system, the air oil cooler of version A has been replaced by version B.

Air oil coolers of version B cannot be installed in vehicles with version A.

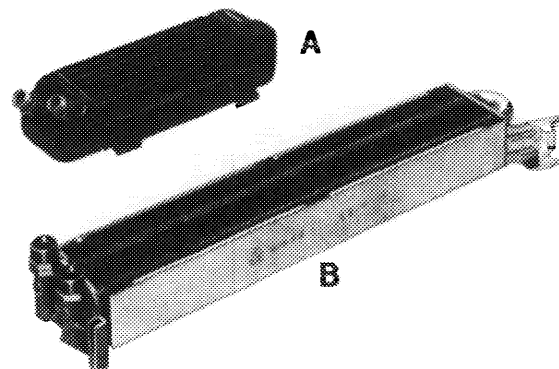

### Air oil cooler and thermostat in oil filter

---

Engine with air oil cooler and thermostat in oil filter

---

615 only on vehicles with air conditioning system

---

616 standard up to June 1978, starting July 1978 on vehicles with air conditioning system only

---

617 general

---

### Oil pressure

---

At operating temperature, the oil pressure at idle may drop to 0.5 bar gauge pressure (atü).

During acceleration, the oil pressure should immediately rise again and attain at least 3 bar gauge pressure (atü) at 3000/min.

In the event of complaints about trembling of oil pressure gauge needle, the throttle pin, part No. 123 542 00 74 can be installed in pressure gauge line at instrument end with tip first.

### Pressure relief valves

---

|  |                          |
|--|--------------------------|
| Opening pressure of pressure relief valves | bar gauge pressure (atü) |
| Bypass valve (8) in oil filter             | 3.5                      |
| Pressure relief valve on oil pump          | 7                        |
| <b>Thermostat — oil filter engine 617</b>  | °C                       |
| Begin of opening                           | 95 ± 4                   |
| Fully opened                               | 110 ± 4                  |

---

### Pressure relief valve on oil pump

---

The dampened oil pressure relief valve (7 bar gauge pressure) is screwed to oil pump.



At no or insufficient oil pressure, check whether oil pressure relief valve has dropped from oil pump or has become loose.

In both cases, coat threads on oil pressure relief valve with sealing compound, part No. 002 989 94 71 and screw-in.

### Bypass valve in oil filter

The bypass valve (8) opens when the differential pressure between the dirty and the clean side of the filter exceeds 3.5 bar.

This will happen when the filter element is badly contaminated. The oil will then flow to engine in uncleaned condition.

- 8 Bypass valve
- a from oil pump
- b to main oil duct

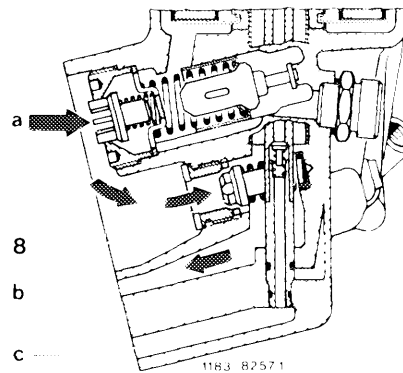

### Oil filter

The main and bypass filter element are combined in a cartridge.

During the first inspection (500–1000 km), replace initial operation filter element (1) with combination filter element (2).

- 1 Initial operation oil filter element
- 2 Combination filter element

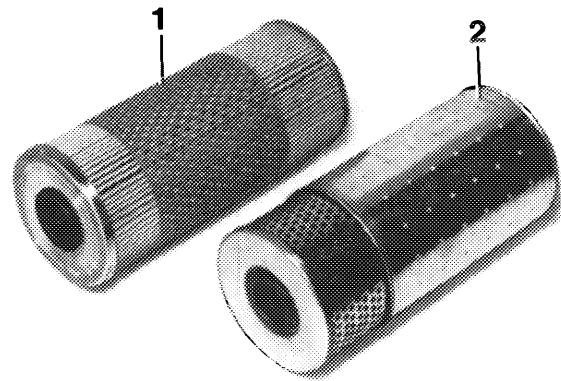

118-11286

Then replace combination filter element during oil change every 5000 km.

Filter element (B), part No. 617 184 01 25 replaces filter element, part No. 617 184 00 25 and can be installed in all diesel engines with upright oil filter.

On the other hand, do not install filter element, part No. 617 184 00 25 in engine 617.950.

- A Combination filter element dimension a = 40 mm
- B Combination filter element dimension b = 55 mm

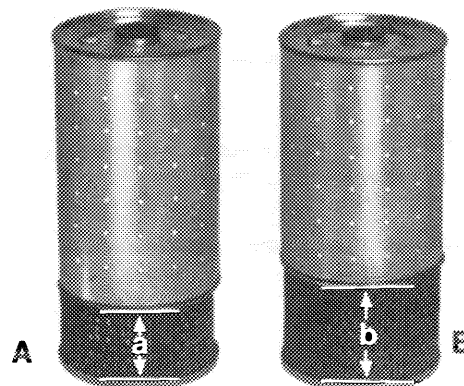

118-13635/2

## 1st version

Up to October 1976, the oil filter cover has been attached with a central bolt (1). The central bolt (1) is simultaneously the return flow pipe for the fine-filtered engine oil.

The central bolt has no check valve.

- 1 Central bolt
- 8 Bypass valve
- 16 Filter element
- 22 Header pipe
- 24 Sealing ring

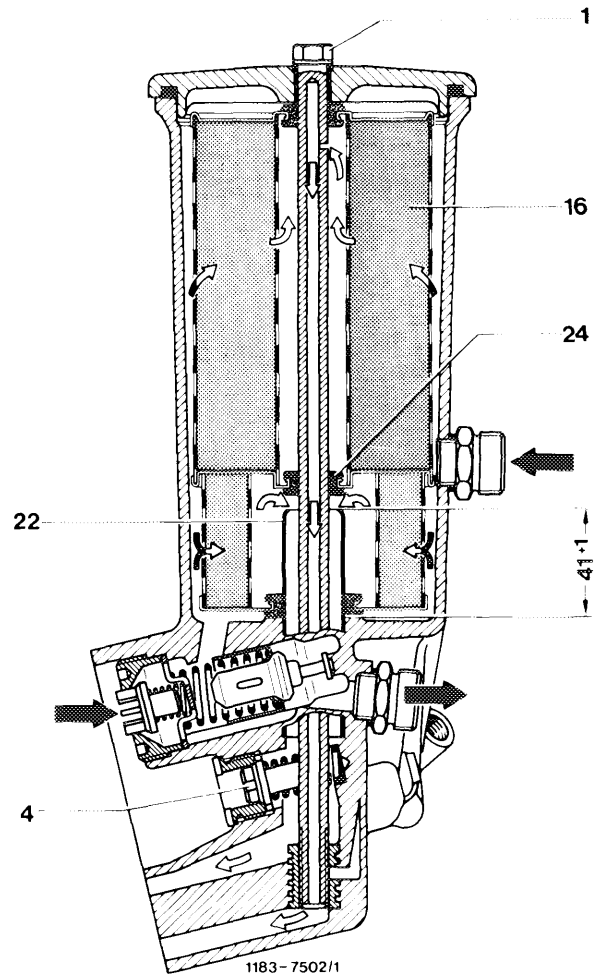

When changing the filter element, loosen central bolt and pull out until the throttle bore (arrow) projects about 5 mm above housing cover. As a result, the return flow duct in filter housing lower half will no longer be closed by the central bolt and the engine oil can flow back into oil pan.

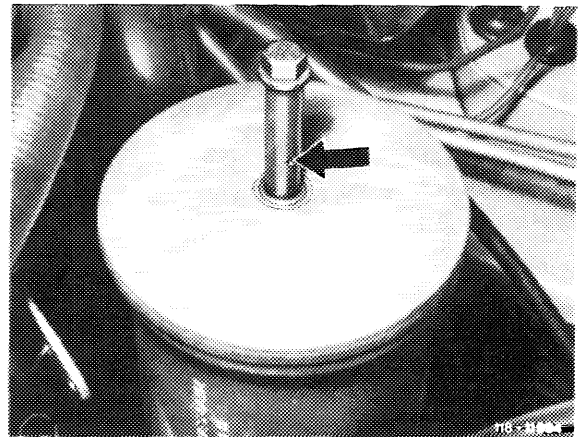

## 2nd version

Starting November 1976, the oil filter cover is attached by means of two nuts.

The return flow pipe (18) is pressed into cover and is provided with a check valve (19).

When changing the filter element, unscrew cover (3) and pull up for a given distance. As a result, the return flow pipe (18) on cover will free a bore which connects the ducts (b) and (c) with each other. The oil in oil filter will flow into oil pan through duct (c).

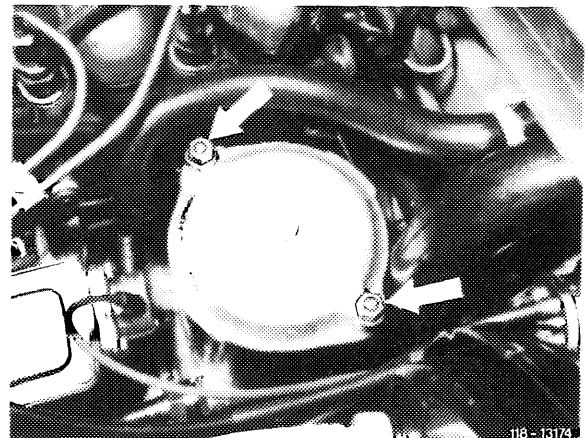

## Operation

The oil filter comprises the following main components:

- a) Oil filter housing with bypass valve, return flow locking valve and thermostat.
- b) Cover with return flow pipe, check valve and sealing ring.
- c) Combination filter element.

- |                           |   |
|---------------------------|---|
| 1 Nut M 8                 | 17 Valve seat return flow locking valve |
| 2 Stud M 8                | 18 Return flow pipe                     |
| 3 Cover                   | 19 Check valve                          |
| 4 Sealing ring            | 20 O-ring                               |
| 5 Oil filter housing      | 21 O-ring                               |
| 6 Threaded connection     | 22 Header pipe                          |
| 6a Threaded connection    | 23 Connection for oil pressure gauge    |
| 7 Compression spring      | A Uncleaned oil to air oil cooler       |
| 8 Star valve              | B Uncleaned oil from air oil cooler     |
| 9 Valve seat bypass valve | a from oil pump                         |
| 10 Compression spring     | b to bearing points                     |
| 11 Thermostat             | c fine-filtered oil to oil pan          |
| 12 Control valve          | d oil return flow bore to oil pan       |
| 15 Compression spring     |   |
| 16 Star valve             |   |

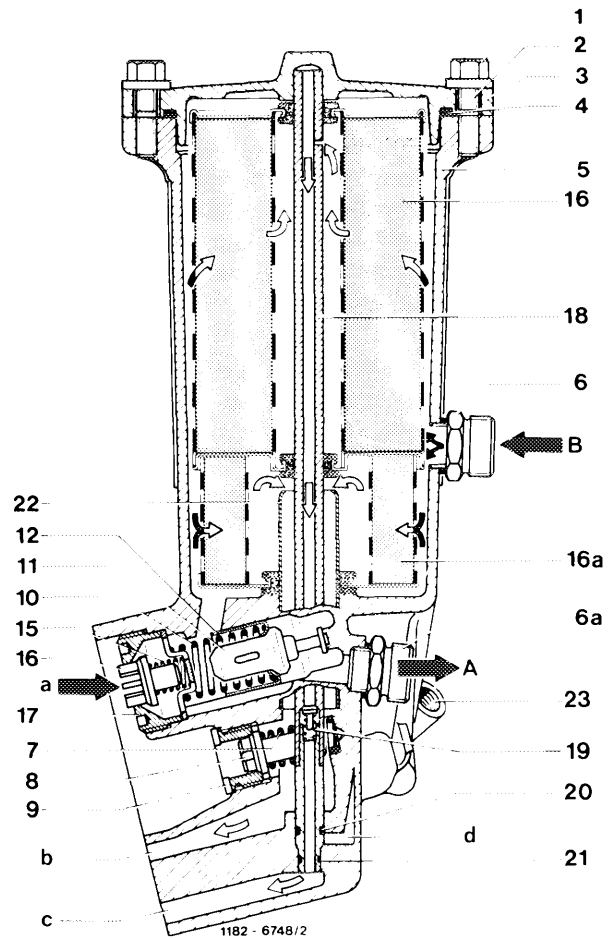

Coming from feed duct (a), the oil flows through return flow locking valve (16 and 17) into oil filter housing and flows directly to combination filter element.

After flowing through combination filter element, the oil, which has been cleaned in main flow filter element (16a), continues flowing through header pipe (22) and duct (b) to main oil duct and on to bearing points.

On the other hand, the oil, which has been fine-filtered in bypass filter section (16), flows through return flow pipe (18) and duct (c) to oil pan.

To keep the main flow and the bypass flow separate, a rubber seal is inserted in combination filter element.

- |                     |                                |
|---------------------|--------------------------------|
| a from oil pump     | c fine-filtered oil to oil pan |
| b to bearing points | e oil pressure gauge           |

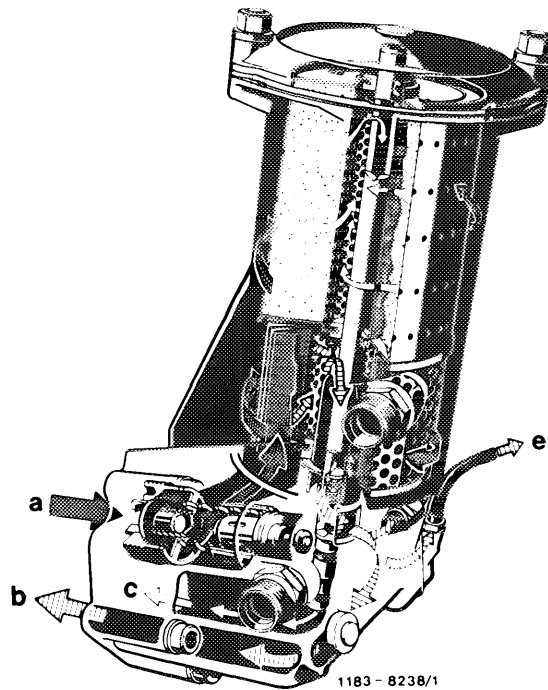

## Engine 617 and engines 615, 616 with air oil cooler

Starting at an oil temperature of approx. 95°C, the thermostat (11) begins displacing the control valve (12), which will attain its end position at approx. 110°C. In the end position, the direct flow to combination filter element is closed except for a given quantity of oil (g). This oil quantity is enough to guarantee lubrication of engine at low outside temperatures, when the through-flow in oil cooler is considerably detained by the now viscous oil.

The major oil quantity arrives at air oil cooler where it is cooled and then flows back to oil filter housing and through oil filter housing from outside in.

The cleaned oil flows through header pipe (22) or return flow pipe (18) to bearing points or into oil pan.

- |   |                     |   |   |
|---|---------------------|---|---|
| A | to air oil cooler   | c | fine-filtered oil to oil pan                        |
| B | from air oil cooler | e | oil pressure gauge                                  |
| a | from oil pump       | g | oil quantity directly to combination filter element |
| b | to bearing points   |   |   |

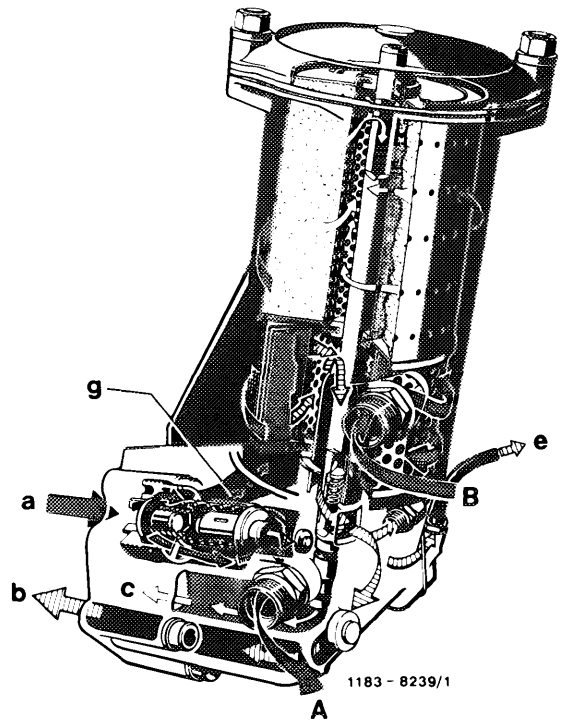

If the filter element is badly contaminated and the differential pressure between the dirty and the clean side of the filter exceeds 3.5 bar, the bypass valve (8 and 9) opens. The oil will then flow to engine in uncleaned condition.

The return flow locking valve (16 and 17) and the check valve (19) in return flow pipe (18) prevent the oil from oil filter flowing back into oil pan when the engine is shut off for longer periods.

- |   |                    |
|---|--------------------|
| a | from oil pump      |
| b | to bearing points  |
| e | oil pressure gauge |

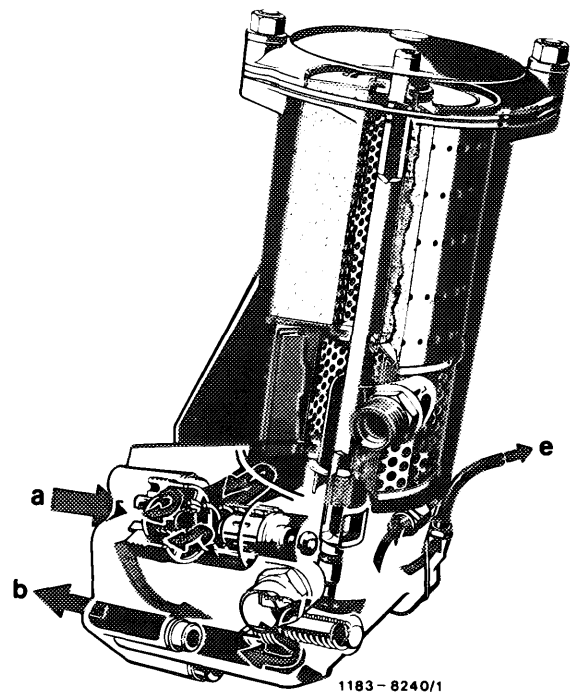

## Complaints concerning oil filter

1 On oil filter 1st version, the oil may flow from oil filter housing back into oil pan after an extended period of inoperation of engine. As a result, the following faults will occur:

- a) Delayed indication of oil pressure by pressure gauge.
- b) Oil level in engine too high.

**Note:** Replacement of oil filter because of these complaints is not justified, since in this connection any fears concerning subsequent bearing damage are unfounded. The lubrication of the bearing points is guaranteed by the residual oil in bearing points in spite of a delayed response of the oil pressure gauge.

2 If following a change of filter element an oil pressure (0.5 atü) is indicated at idle speed, observe the following:

Excessive force when inserting central bolt (1) during a filter change may push the sealing ring (24) out of its hold into a position in front of header pipe (22). The oil will then be supplied via the overflow valve (8) which will result in a drop in oil pressure. To avoid pushing out sealing ring (24), insert central bolt (1) into oil filter without using force.

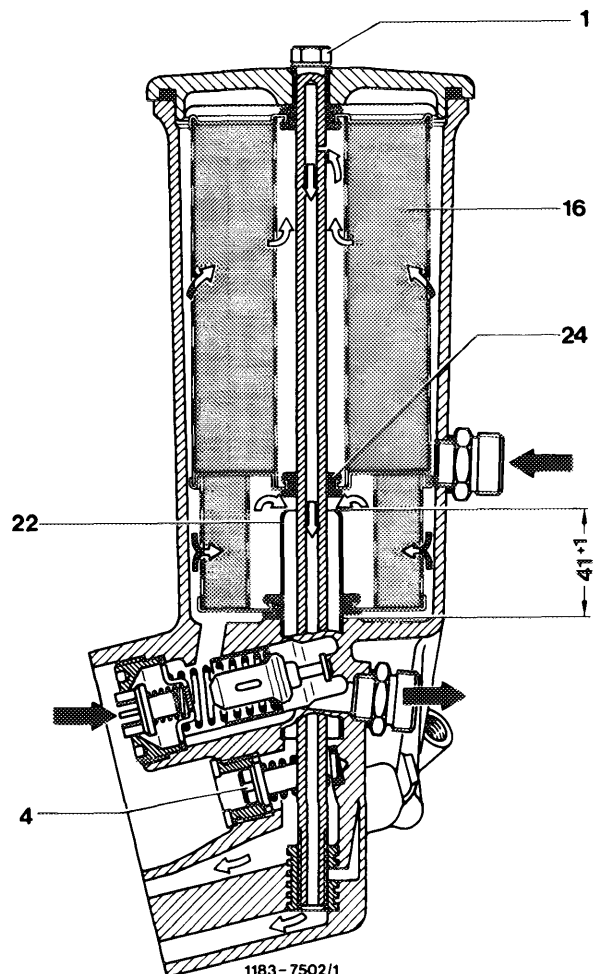

Check pressing-in depth of riser pipe in oil filter.  
Height of riser pipe from upper edge of pipe up to contact surface of filter element should not exceed  $41 + 1$  mm. If the height exceeds 42 mm, renew complete oil filter.