

Under influence of decreasing fuel level the sliding contact (1) on float (2) of immersion tube transmitter will increase the resistance value, the current will decrease and the indicator needle in instrument will then fall back.

If the fuel level drops still further, the reserve warning contact (5) in immersion tube transmitter, which connects to reserve warning lamp ground, is closed.

Immersion tube transmitter

- 1 Sliding contact
- 2 Float
- 3 Contact plate
- 4 Guide and contact rod
- 5 Reserve warning contact

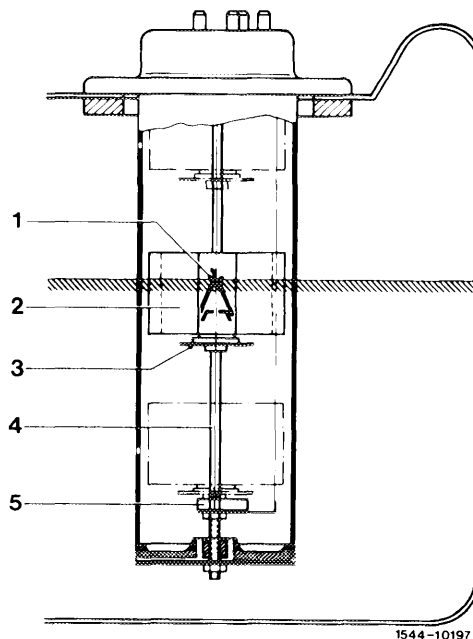

The circuit has been changed starting September 1982. With the ignition switched on, the reserve warning lamp will light up (checkup function). As soon as the engine is running, the lamp will go out, provided the fuel tank holds more fuel than reserve.

Note: During checkup function, the reserve warning lamp lights up weaker, with reserve stronger.

Sedan and coupe up to August 1982

- 1 Immersion tube transmitter
- 2 Fuel indicator
- 4 Plug connection tail lamp harness
- a To terminal 15

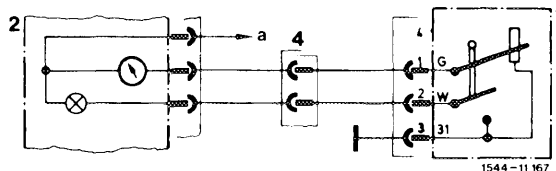

Model 123 sedan and coupe starting September 1982

- 1 Immersion tube transmitter
- 2 Fuel indicator
- 4 Plug connection, tail lamp harness
- a To terminal 15
- b To terminal 61

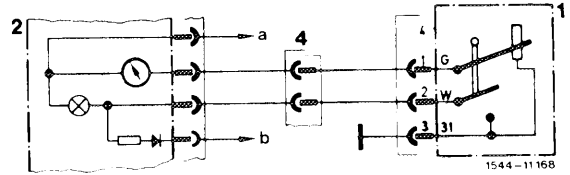

On T-sedans and special vehicles with special body the coupler of the immersion tube transmitter is provided with a compensating resistor 4.7 ohm (color rings yellow/purple/gold/gold). As a result, the same indicator can be used with different fuel tanks.

T-sedan up to August 1982

- 1 Immersion tube transmitter
- 2 Fuel indicator
- 4 Plug connection, tail lamp harness
- 5 Resistor 4.7 ohm
- a To terminal 15

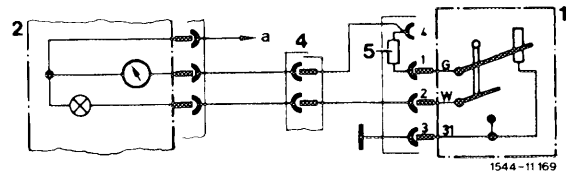

T-sedan starting September 1982

- 1 Immersion tube transmitter
- 2 Fuel indicator
- 4 Plug connection, tail lamp harness
- 5 Resistor 4.7 ohm
- a To terminal 15
- b To terminal 61

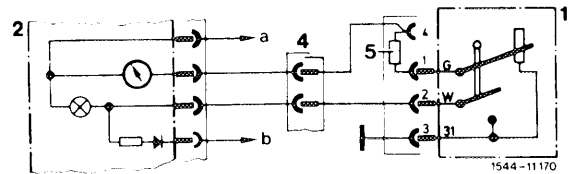

Check fuel gauge (54-269).