

46–630 Removal and installation of steering shaft

Data

Length "a" of steering shaft (reference dimension)	power steering	322 ± 0.5
	manual steering	369 ± 0.5

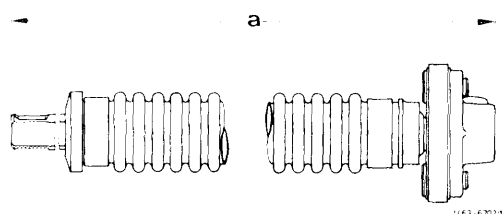

Tightening torque

Hex socket screws to steering coupling

Nm

25

Removal

1 Unscrew both hex socket screws (13) from steering coupling (2).

2 Slip steering coupling completely on splining of steering worm.

Note: Slightly push steering coupling apart at joint so that the coupling slides easily on flat profile of steering shaft and splining of steering worm.

3 Remove cover at left under instrument panel.

4 Unscrew hex socket screw (42) from steering coupling.

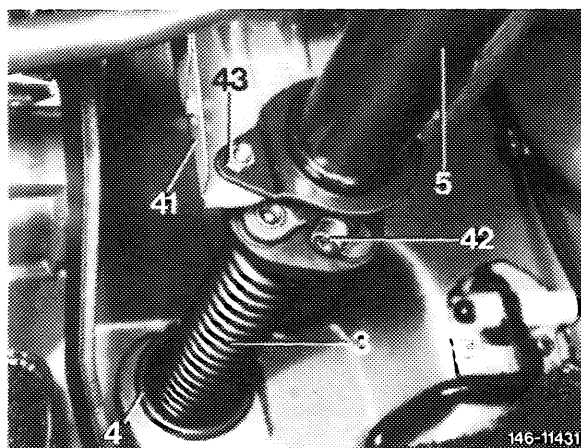
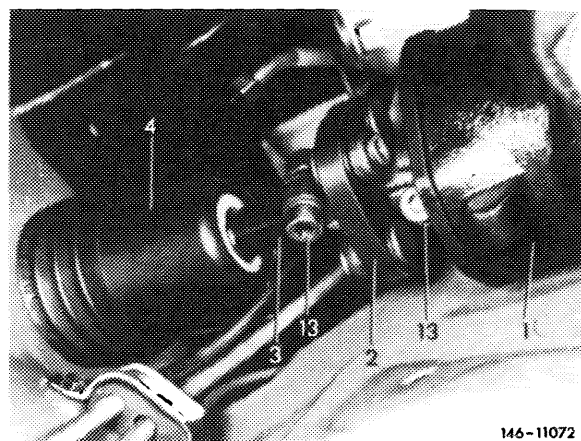

5 Push lower steering shaft forward toward steering until the steering coupling is no longer in flat profile of upper steering shaft.

6 Remove lower steering shaft in lateral direction.

Note: Do not use force. Due to its structural design the corrugated tube of the lower steering shaft is relatively sensitive against lateral forces.

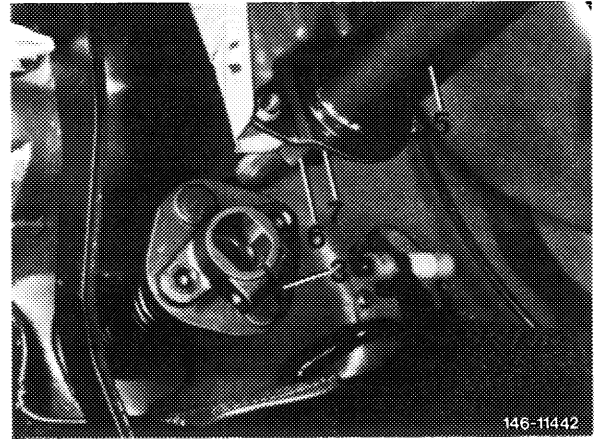

Checkup

7 Check condition and correct seat of rubber sleeve (4) in front end.

8 Slightly coat rubber sleeve in range of the two sealing lips with "Shell Retinax A" (arrow).

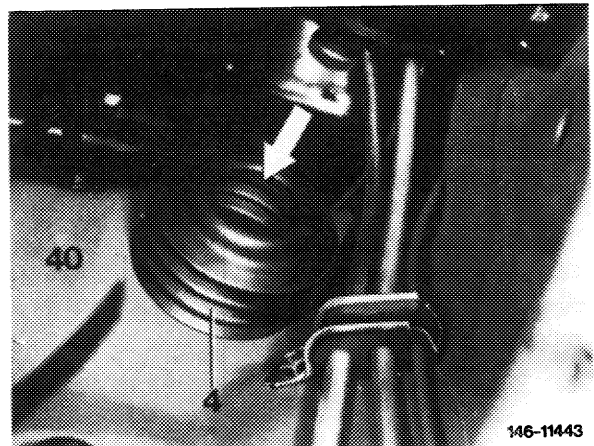

9 Check length and concentricity of lower steering shaft (max. lateral runout in range of corrugated tube 2 mm).

10 Check steering coupling (3a) on lower steering shaft and completely renew lower steering shaft, if required.

11 Slightly coat sealing ring (3b) of lower steering shaft with "Shell Retinax A".

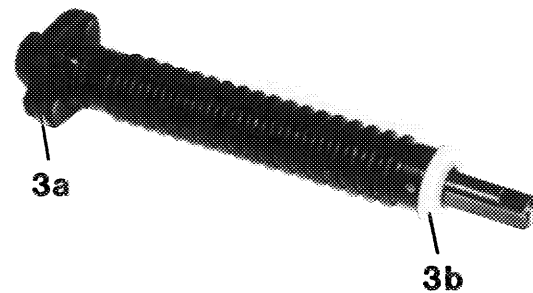

Installation

12 Introduce lower steering shaft through rubber sleeve into steering coupling on steering worm.

Push steering shaft completely toward steering gear.

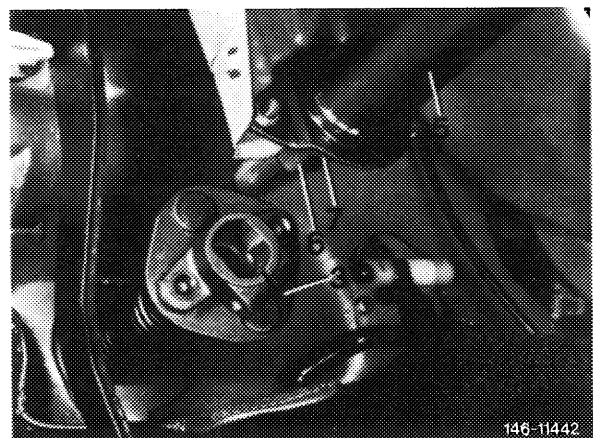

13 Turn upper steering shaft so that the steering coupling of the lower steering shaft can be slipped on flat profile. The recess on the flat profile of the upper steering shaft should face screw end of steering coupling. This is necessary so that during a subsequent assembly the hex socket screw can be screwed into steering coupling.

14 Slip lower steering shaft (3) up to stop ring (7) of upper steering shaft. Screw-in hex socket screw and tighten to 25 Nm.

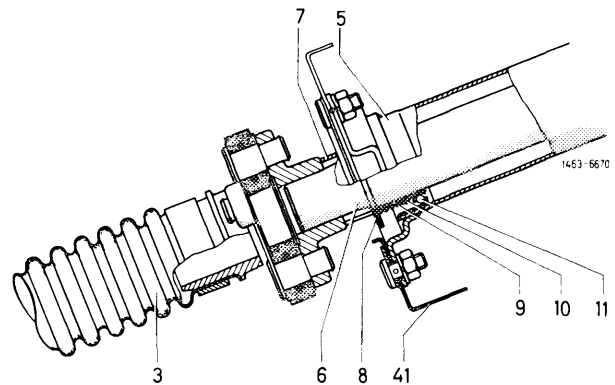

15 Slip steering coupling (2) on flat profile of lower steering shaft upwards until coupling is no longer in splining of steering worm.

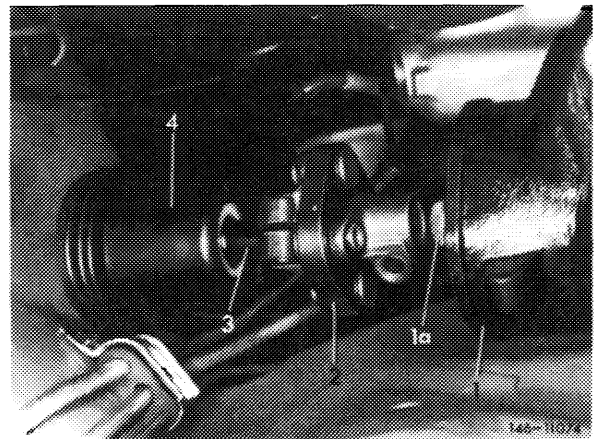

16 At straightahead position of wheels, turn steering wheel in such a manner that the spokes are horizontal; the slightly curved spoke should be below.

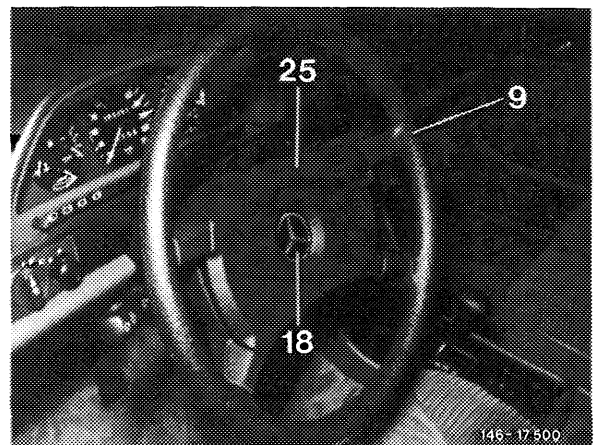

17 In this position, slip steering coupling on steering worm, screw-in both hex socket screws and tighten to 25 Nm.

18 During trial run, check position of steering wheel in straightahead position of road wheels. If the steering wheel position when driving straightahead is not in agreement with front wheels, the steering wheel can be displaced in splining by max. 2 teeth to the left or right.

Note: If the position of the steering wheel and the straightahead position of the road wheels is still not yet correct, check toe-in starting from center position of steering and adjust (40–320).

19 Check for perfect seat of rubber sleeve (4) on sealing ring of lower steering shaft (3).

20 Install both covers.

