

## 46–620 Removal and installation of jacket tube

Tightening torques	Nm
Hex nut for attaching steering wheel to steering shaft	80
Hex nuts for attaching jacket tube to cross member	25
Hex nuts for attaching jacket tube to lower mounting bracket	10
Hex socket screw to steering coupling	25

### Removal

- 1 Remove cover at left under instrument panel.
- 2 Remove steering wheel (46–610).

**Note:** On vehicles provided with restraining system (airbag and belt tensioner), pay attention to notes in 46–610, section B.

- 3 Remove instrument cluster, while pulling out instrument cluster as far as possible.
- 4 Loosen tachometer shaft, both electric plug connections and oil pressure line.

On vehicles with automatic transmission and steering column shift, loosen plug connection for shift indicator on instrument cluster.

- 5 On vehicles with automatic transmission and steering column shift, disconnect Bowden wire (9) and remove lock (7).
- 6 Remove steering lock (46–640).

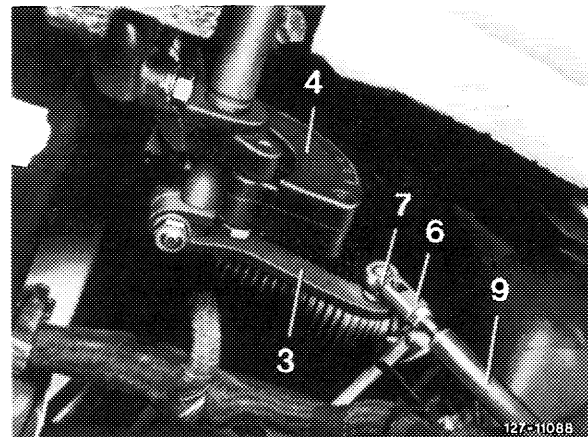

- 7 Unscrew hex socket screw (42) from steering coupling of lower steering shaft (3).
- 8 Unscrew both hex nuts (43) for attaching jacket tube to lower mounting bracket.
- 9 Loosen electric plug connection of combination switch.

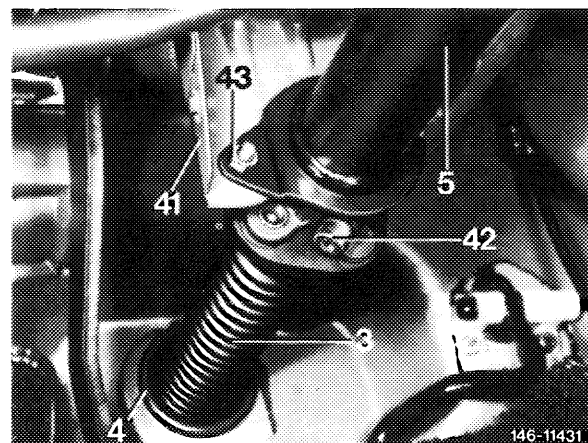

10 Unscrew both hex nuts (53) for attaching jacket tube to mounting bracket (52) (for better illustration the instrument panel has been removed).

11 Push jacket tube downwards and remove, make sure that the lower steering shaft (corrugated tube) is not damaged.

**Note:** Do not use force. Due to its structural design, the corrugated tube of the lower steering shaft is relatively sensitive against lateral forces.

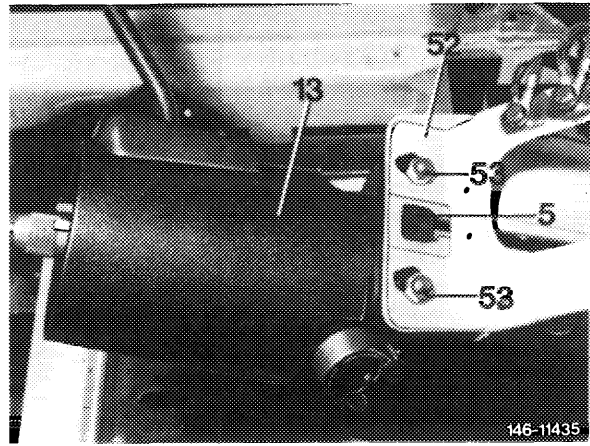

## Installation

12 Introduce flat profile of lower steering shaft (6) into steering coupling of lower steering shaft (3), together with jacket tube into studs of lower mounting bracket (41), as well as with studs on jacket tube into cross member. Mount snap rings or washers, screw-on hex nuts and tighten.

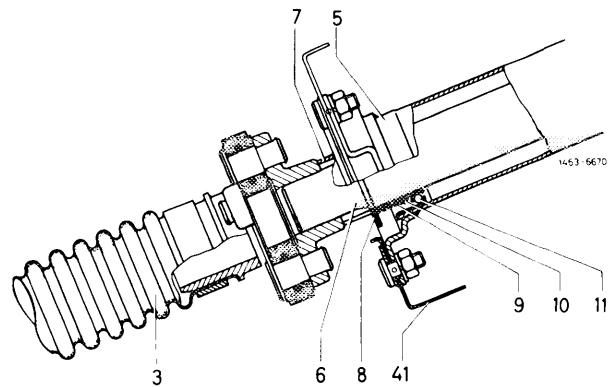

**Note:** When installing jacket tube, do not damage lower steering shaft (corrugated tube). Also note that the reserves on flat profile of upper steering shaft faces screw end of steering coupling, so that the hex socket screw can subsequently be screwed into the steering coupling.

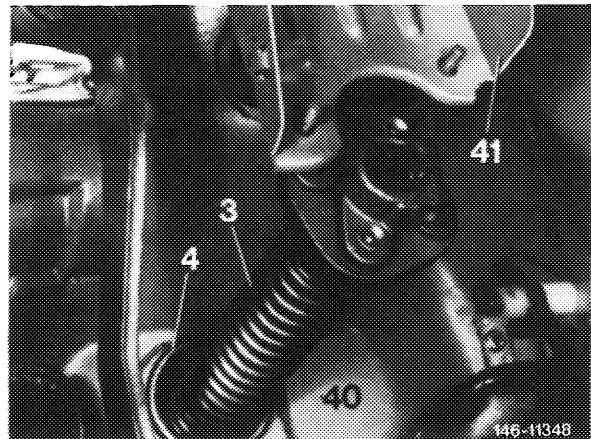

13 Screw hex socket into steering coupling and tighten to 25 Nm.

**Note:** The lower steering shaft should rest against spacing ring of upper steering shaft.

14 Connect electric plug connection of combination switch.

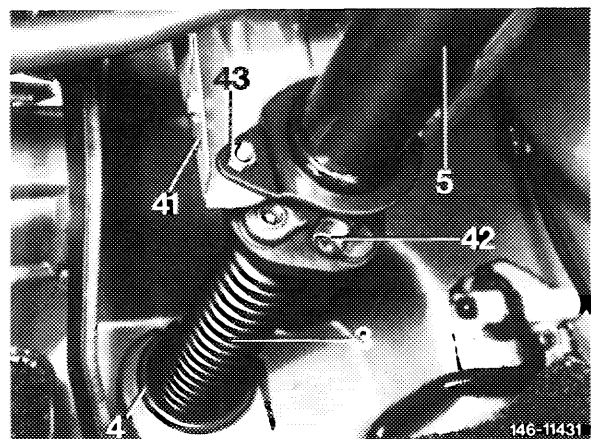

15 Install steering lock (46–640).

16 On vehicles with automatic transmission and steering column shift, attach Bowden wire to shift tube.

17 Install instrument cluster and connect both electric plug connections, the oil pressure line and the tachometer shaft, in addition on vehicles with automatic transmission and steering column shift also the plug connection of the shift indicator on instrument cluster.

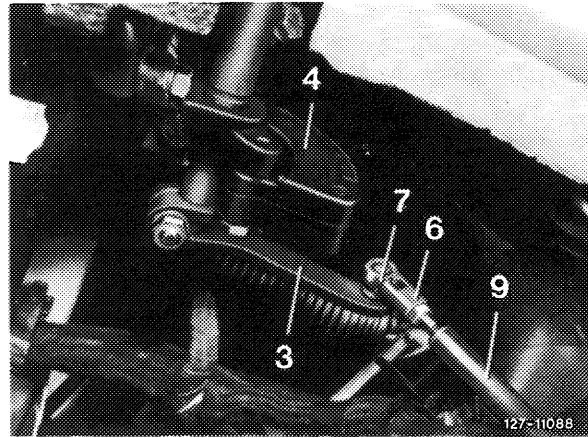

18 Install both covers.

19 Install steering wheel (46–610).

20 Check function of combination switch.

21 During trial run, check position of steering wheel in straightahead position of road wheels. If the steering wheel position when driving straightahead is not in agreement with front wheels, the steering wheel can be displaced in splining by max. 2 teeth to the left or right. For this purpose, unscrew lower hex. socket screw (13) on steering coupling (2) and loosen upper screw.

22 Slide steering coupling from steering worm (1a) to lower steering shaft. Turn steering wheel to the left or right (max. 2 teeth) into correct position.

Slide steering coupling on steering worm, screw in both hex. socket screws and tighten to 25 Nm.

**Note:** If the position of the steering wheel and the straightahead position of the road wheels is still not yet correct, check toe-in starting from center position of steering and adjust (40–320).

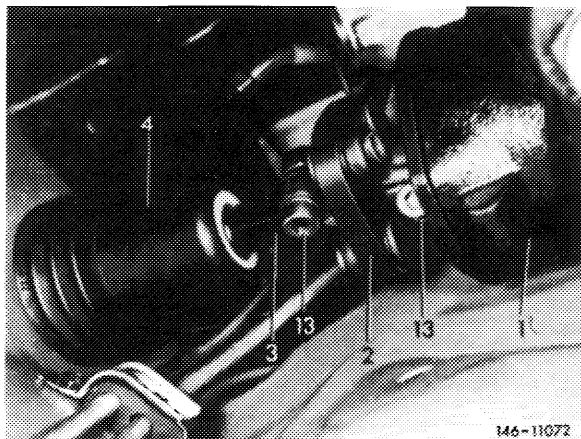

**Self-made tools**

Thrust piece	refer to Fig., item 9 note
Assembly tool	refer to Fig., item 14 note

**Disassembly**

- 1 Remove jacket tube (46-620).
- 2 Loosen two slotted screws (49) on combination switch and remove cables of twin contact carbon from plug connection. Remove twin carbon.
- 3 Unscrew both Philips head screws (48) and remove combination switch.

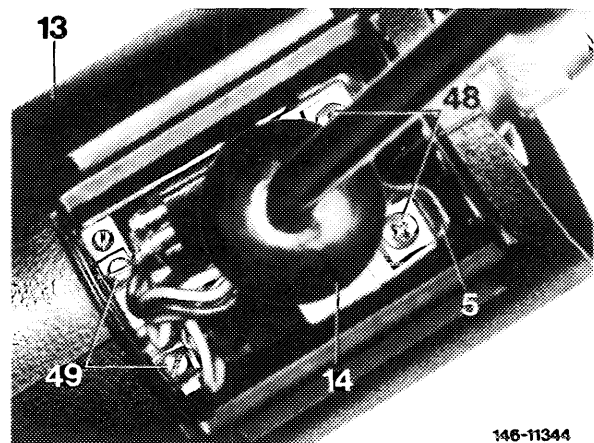

146-11344

- 4 Screw both combination screws (47) out of jacket tube and remove jacket tube lining (13).

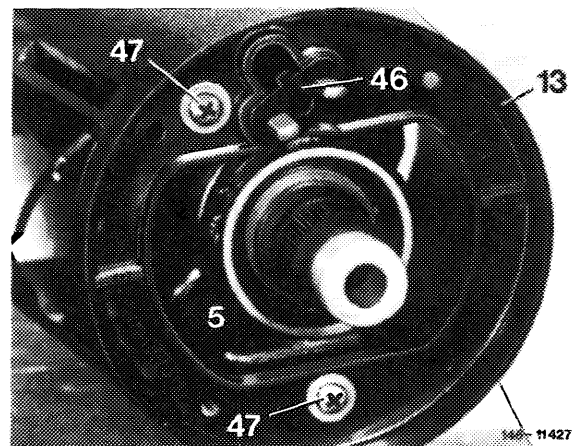

146-11427

**Jacket tube 1st version**

- 5 Remove spacing ring (7) from steering shaft.

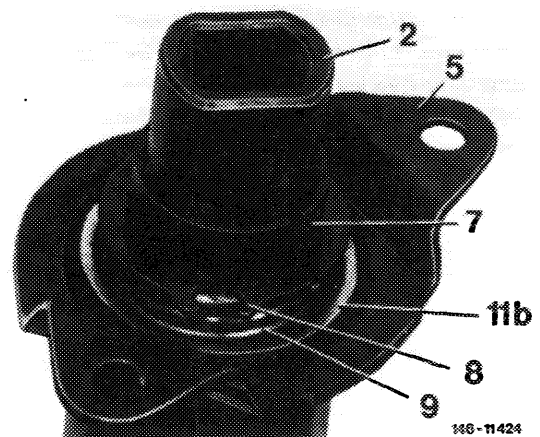

146-11424

6 Remove grip ring (8) and then compression spring (9), supporting ring (10) and ball bearing (11) from steering shaft.

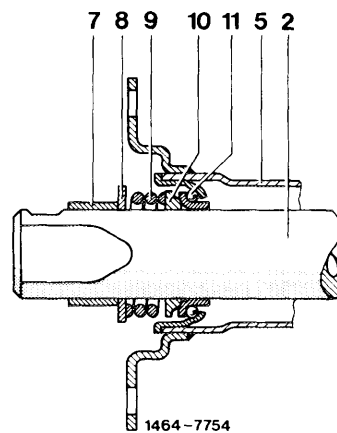

**Jacket tube 2nd version**

7 Remove grip ring (8), plate spring (15), supporting ring (16) and ball bearing (11) from steering shaft.

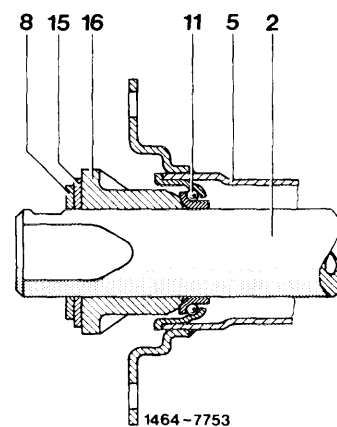

8 Remove locking ring (12), supporting ring (10) and ball bearing (11) from both versions.

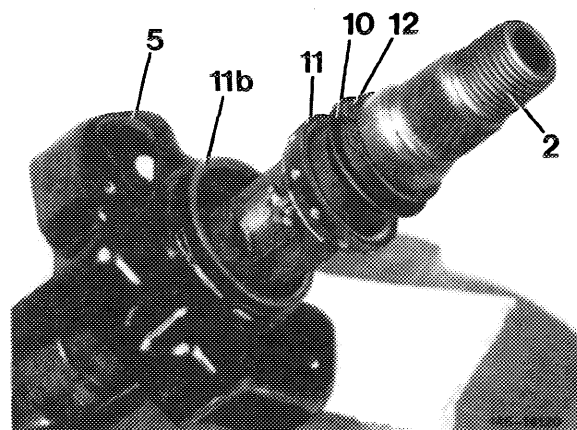

9 Insert thrust piece (050) into jacket tube and knock outer race (11 b) of upper ball bearing out of jacket tube with steering shaft. Then remove outer race of lower ball bearing out of jacket tube also using thrust piece.

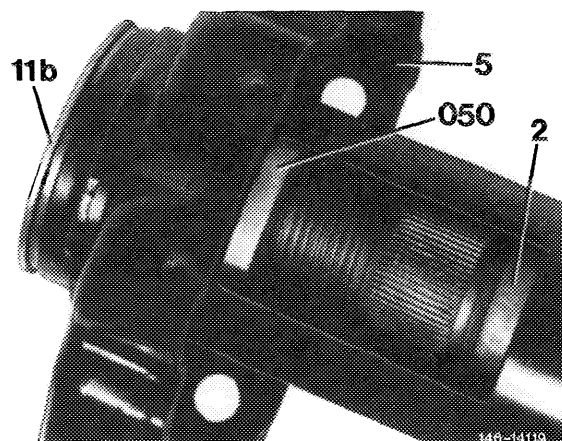

**Note:** The thrust piece is self-made according to specified dimensions.

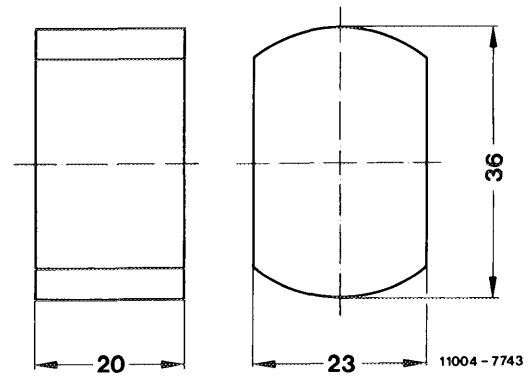

## Installation

10 Prior to installation, check both ball bearings for wear and replace bearings, if required.

11 Press outer race (11 b) of upper ball bearing into jacket tube. Insert steering shaft into jacket tube and press-in lower outer race.

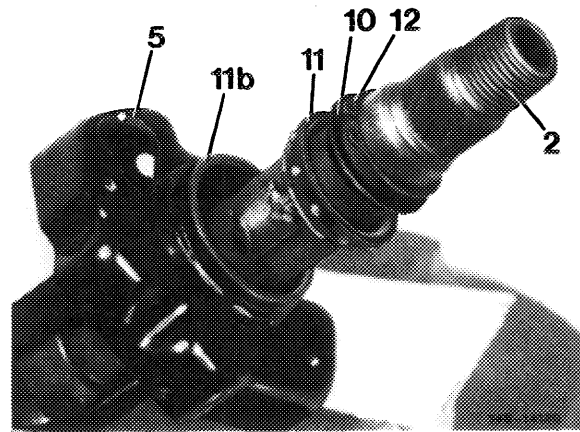

12 Place ball bearing (11) and supporting ring (10) on steering shaft, then insert locking ring (12).

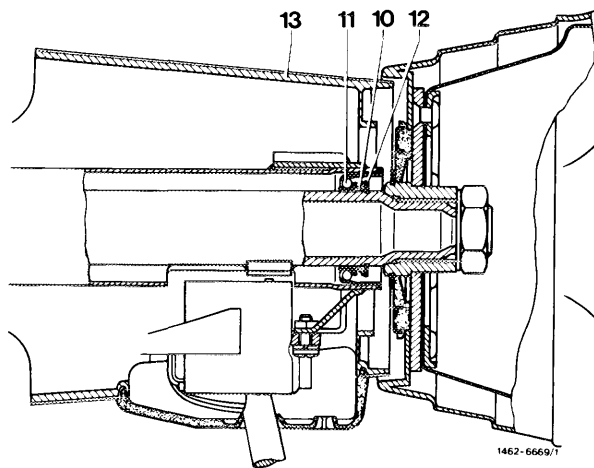

13 On jacket tube 1st version, place ball bearing (11), supporting ring (10) and compression spring (9) on steering shaft.

14 Position grip ring on steering shaft and force on steering shaft by means of assembly tool until compression spring is completely compressed.

**Note:** The assembly tool is self-made according to specified dimensions.

The guide piece welded into tube can be made from a steering shaft of models 114, 115 or 116.

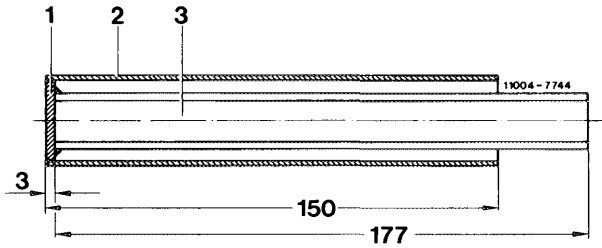

15 Slip spacing ring (7) on steering shaft.

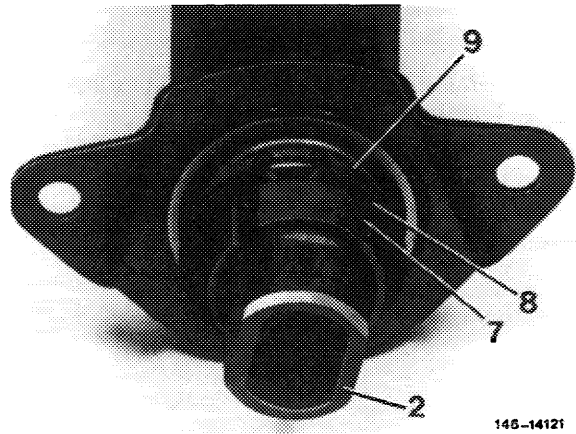

16 On jacket tube 2nd version, place ball bearing, supporting ring (16) and plate spring (15) on steering shaft.

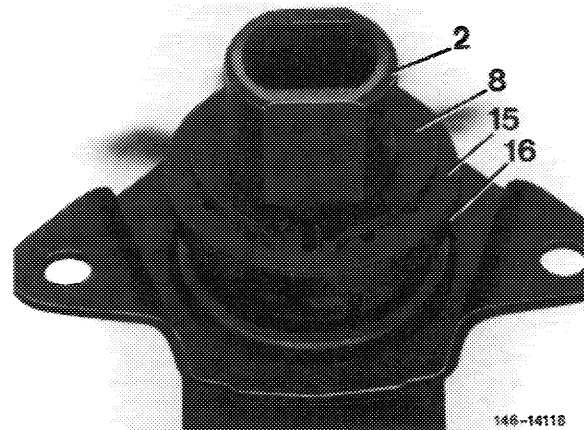

17 Position grip ring (8) on steering shaft and press on steering shaft by means of assembly tool until plate spring (15) is completely preloaded.

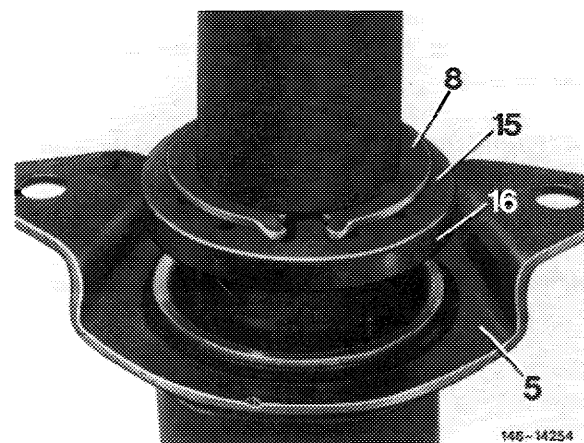

18 Attach jacket tube lining with two combination screws to jacket tube. Insert twin contact carbon.

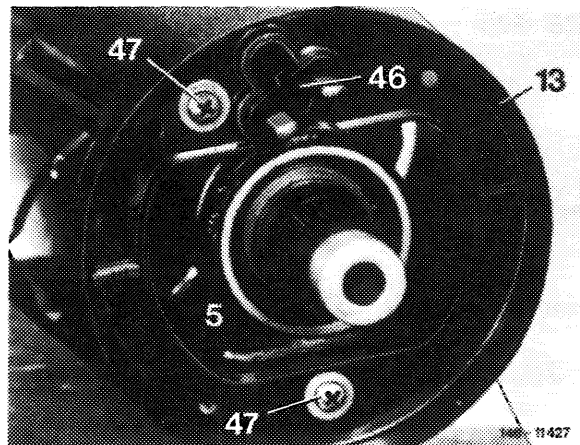

19 Insert combination switch into jacket tube. Prior to attaching combination switch, connect both cables of twin carbon. Knot cover for combination switch into lining.

