

**Notes**

The supporting joint requires no service and consists of a ball joint which is supported toward the front and the rear by one rubber thrust bearing each. The ball pin of the joint is supported in plastic shells.

As a spare part, the supporting joint is available as a complete assembly only.

At the lower control arm, the supporting tube is supported in rubber. The ball pin of the supporting joint is screwed in at the rear and held in place by means of a clamp.

**Checking supporting joint**

Slip a piece of tubing approx. 150 mm long on ball pin. If the joint is in order, the ball pin can be moved back and forth uniformly and tightly, but without binding, but note, that the release torque is higher than the torque required to keep joint moving.

In the event of play, jerky movements only, grating noises or a damaged sleeve (48e), completely replace supporting joint.

The support of the ball pin in the rubber thrust bearings must be free of play.

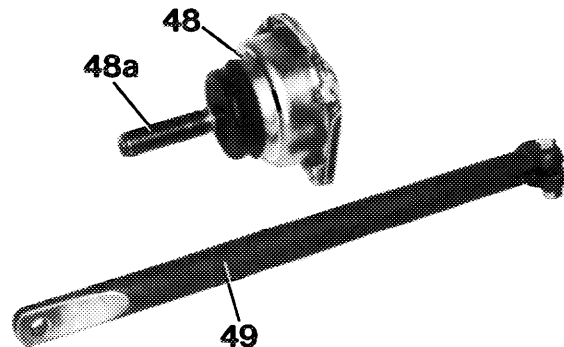
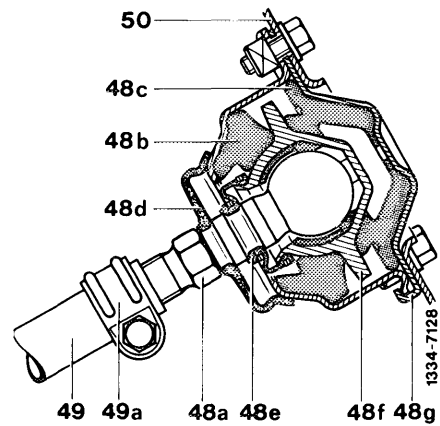

- 48 Supporting joint
- 48a Ball pin (caster adjustment)
- 48b Rubber thrust bearing front
- 48c Rubber thrust bearing rear
- 48d Sealing bellows
- 48e Sleeve
- 48f Housing for ball pin
- 48g Supporting joint housing
- 49 Supporting tube
- 49a Clamp
- 50 Bearing bracket for brake support

On vehicles following an accident, additionally check cover of supporting joint housing (48g) for distortion.

Use pertinent ring for this purpose (self-made).

If cover is in order, it will rest fully against ring (A).

If cover is distorted, a gap will show up between cover and ring (B-arrows).

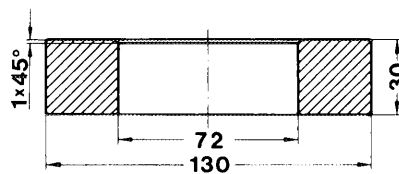
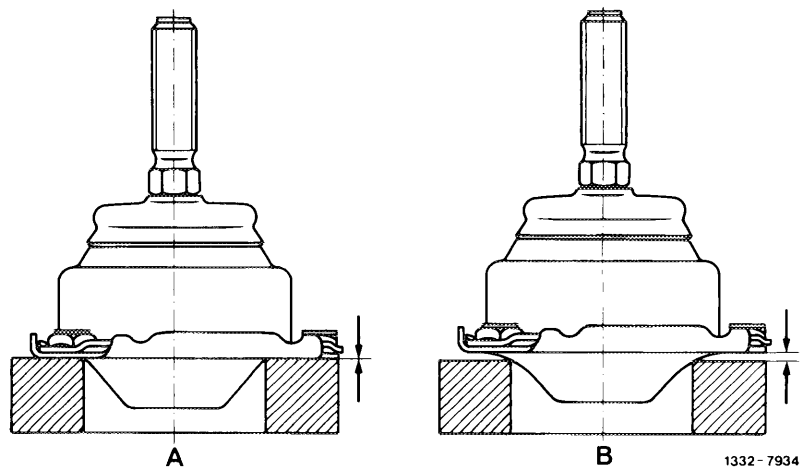

### Checking supporting tube

Check supporting tube for distortion by means of a straightedge.

In addition, measure distance in relation to supporting surface at flat end on both sides. The two dimensions should not deviate from each other by more than 0.4 mm. When measuring, make sure that the supporting tube is not resting on clamp.

Do not straighten distorted supporting tube, but replace on principle.

